

- Per lavorazioni in barra  
For bar machining

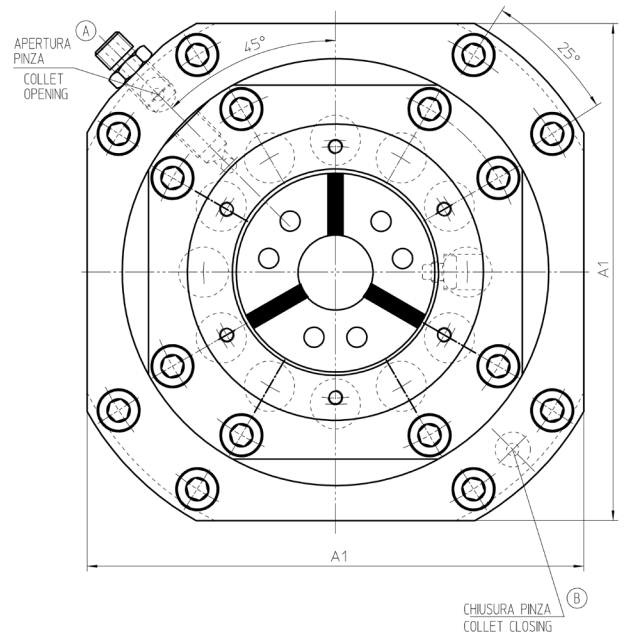
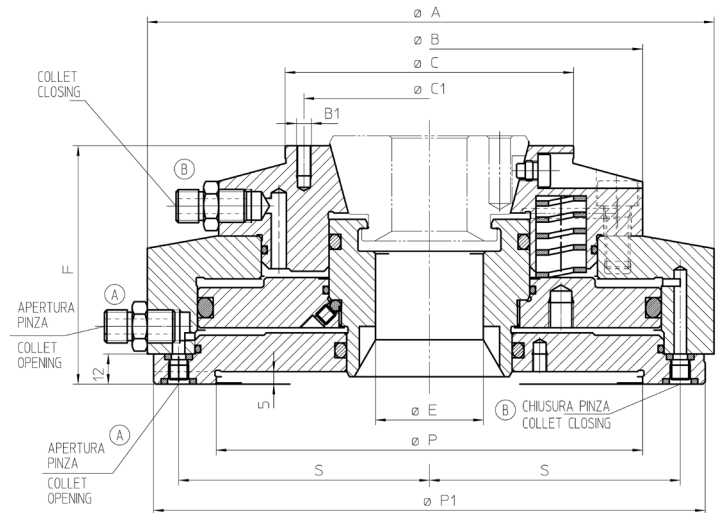
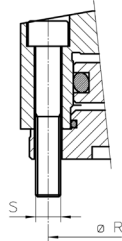

Modello MPT - MPT model	SHP 42	SHP 65
Attacco naso mac. - Machine spindle	Z170 Z220	Z170 Z250
Codice - Code	77740242	77740265
A	227	255
A1	198	218
B	170	200
B1	6xM6	6xM6
C	115	140
C1	100	120
E	43	67
F	95	100
P H7	170	170
P1 h7	220	250
R	205	230
S	8xM10	8xM10
T	100	112.5

Pressione esercizio Operating pressure	bar	7	7
Forza assiale max a metà corsa con molle Max axial force at half stroke with springs	kN	25	28
Forza di serraggio max Max clamping force	kN	50	65

Attrezzo di ricambio Changing unit	SHH 42	SHH 65
Manuale - Manual	00196842	00196844
Pneumatico - Pneumatic	01866500	01866599

**NOTA: per le pinze vedere pagine 54 e 55**  
**NOTE: for collets see page 54-55**

DOTAZIONE: Mandrino e viti di fissaggio  
(pinze da ordinare separatamente)

EQUIPMENT: Chuck and fixing screws  
(collets to be ordered separately)

Con riserva di modifiche tecniche  
Subject to technical changes