

06153000 - TH-CUT P12 UT32 H80

Tipo	TH-CUT Portautensili statico portalama
Attacco	CILINDRICO 40
Uscita utensile	TH porta lama 32
Raffreddamento	Refrigerazione esterna
H [mm]	80

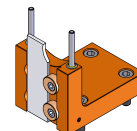

Accessori	N.D.
Note	N.D.
Note per il montaggio	N.D.

Verificare sempre gli ingombri del portautensile in torretta

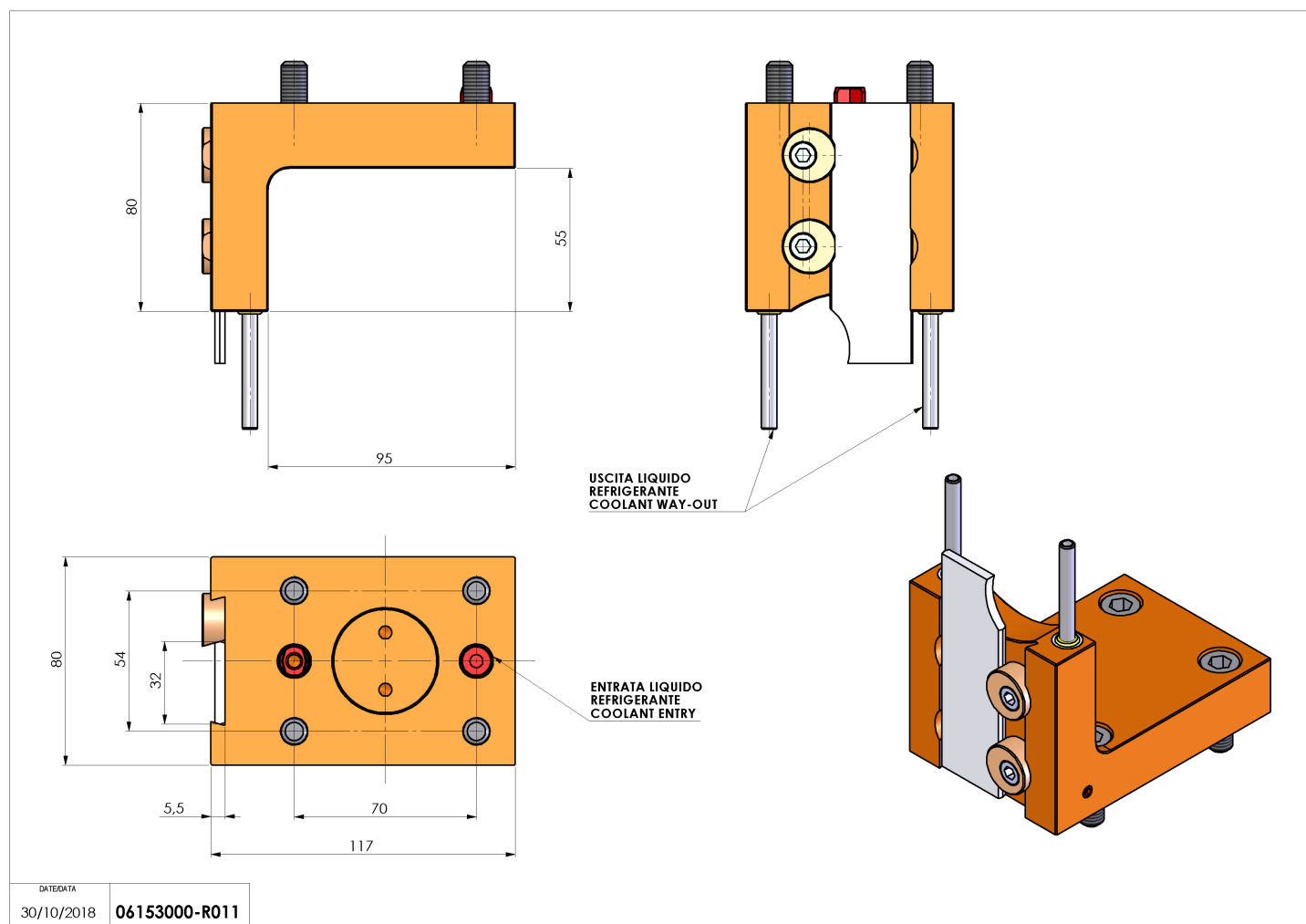

Salvo modifiche tecniche