

05355700 - LT-S2 VDI40 ER32F HRF H99 MZ

Tipo	LT SPECIALE Portautensile motorizzato speciale
Attacco	VDI 40
Uscita utensile	Portapinza ER 32 F - ghiera interna
Raffreddamento	Refrigerazione interna HRF
Senso di rotazione	r1 r2 r3
Velocità max [1/min]	6000
Coppia max [Nm]	63
Rapporto	1:1
H [mm]	99
Pressione max [bar]	80
Accessori	N.D.
Note	N.D.
Note per il montaggio	N.D.

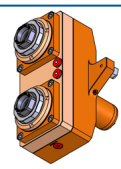

ATTENZIONE: VERIFICARE L'ORIENTAMENTO DELLA DENTATURA VDI

Verificare sempre gli ingombri del portautensile in torretta

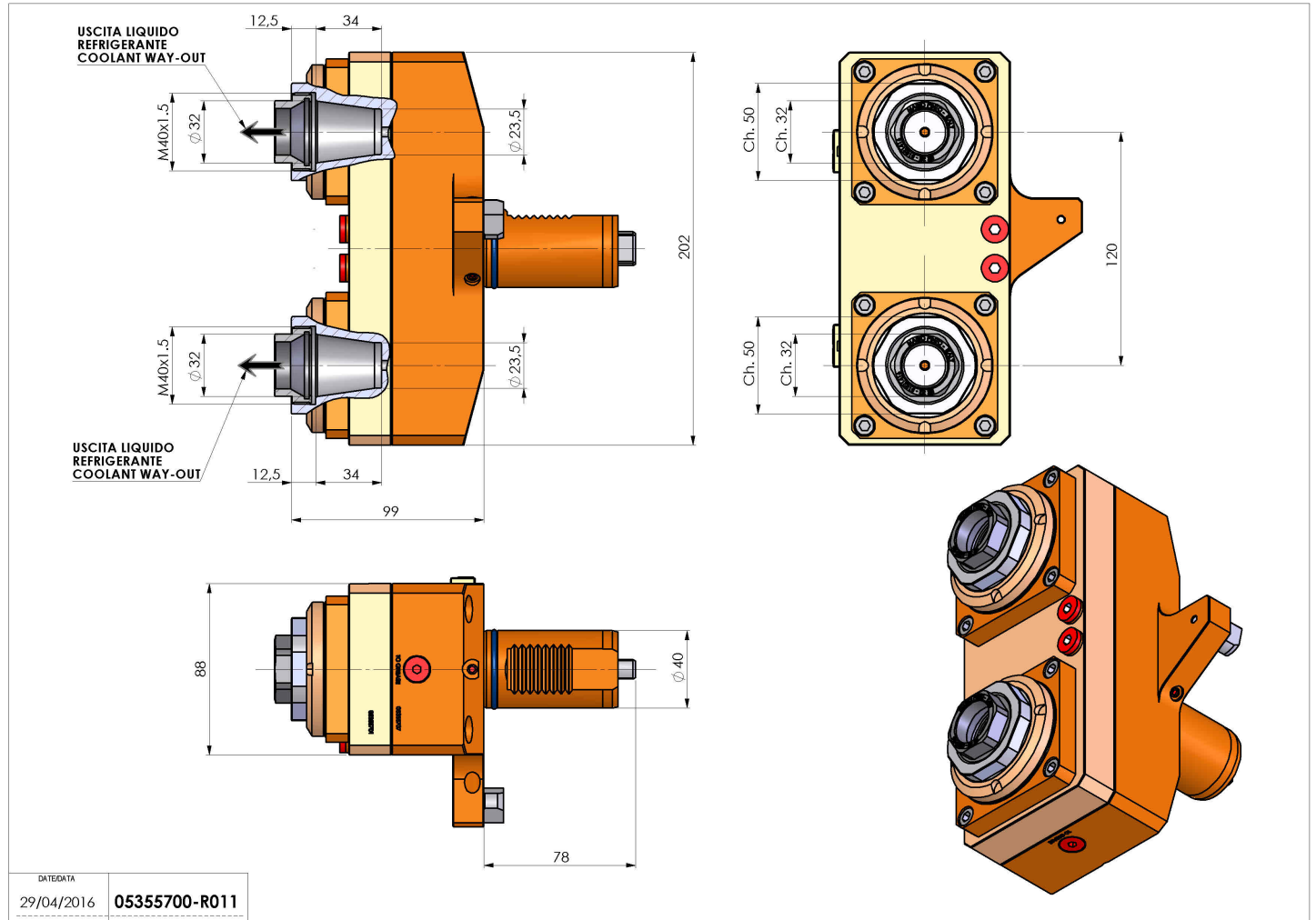

DATE/DATE: 29/04/2016 **05355700-R011**

Salvo modifiche tecniche