

05352000 - LT-S D80 ER32F OFS100 RF H96MZ

Tipo	LT-S OFS Portautensili dritto offset
Attacco	CILINDRICO 80
Uscita utensile	Portapinza ER 32 F - ghiera interna
Raffreddamento	Refrigerazione interna
Offset [mm]	100
Senso di rotazione	r1 r2
Velocità max [1/min]	6000
Coppia max [Nm]	80
Rapporto	1:1
H [mm]	95,5
Pressione max [bar]	20
Accessori	N.D.
Note	N.D.
Note per il montaggio	N.D.

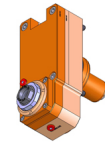

Verificare sempre gli ingombri del portautensile in torretta

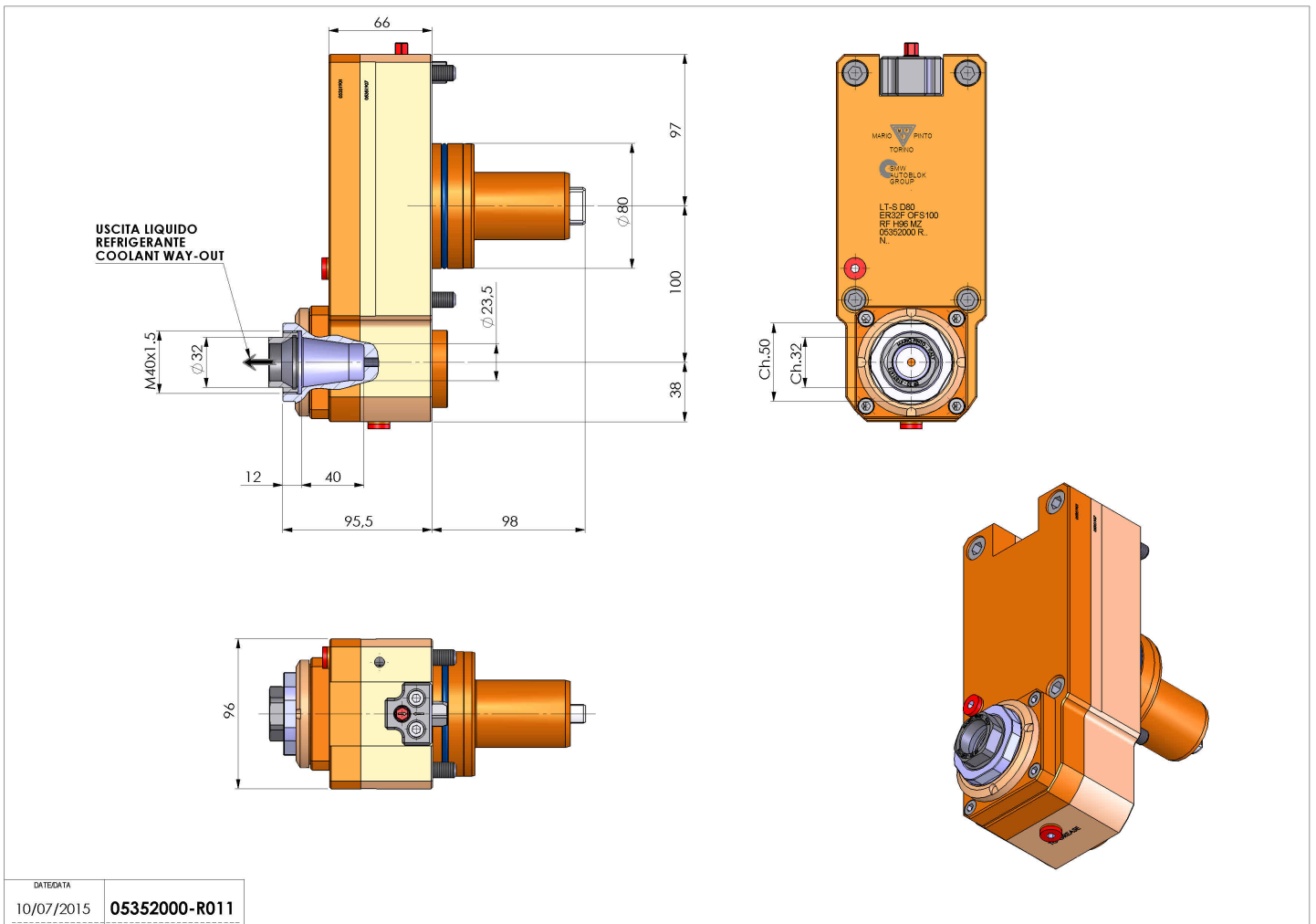

Salvo modifiche tecniche