

05317100 - LT-A BMT55 BD ER25 LR HRF H85

Tipo	LT-A Portautensili angolare a 90°
Attacco	BMT 55 BIG DRIVE
Uscita utensile	Portapinza ER 25
Raffreddamento	Refrigerazione interna HRF
Senso di rotazione	r1 r2
Velocità max [1/min]	6000
Coppia max [Nm]	60
Rapporto	1:1
H [mm]	85
H1 [mm]	32.5
Pressione max [bar]	80
Accessori	N.D.
Note	N.D.
Note per il montaggio	Mandrino principale e secondario

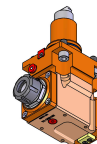

Verificare sempre gli ingombri del portautensile in torretta

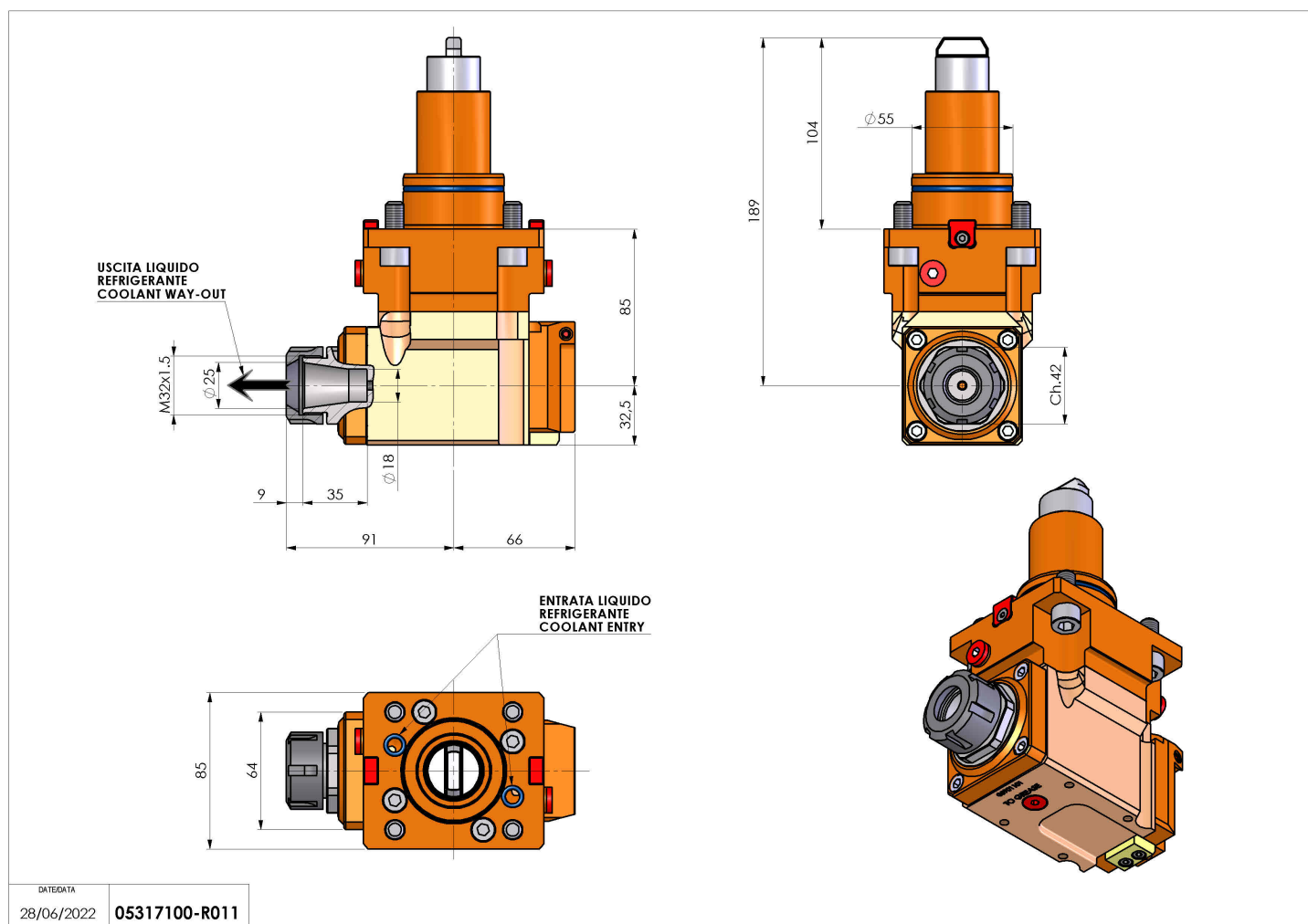

Salvo modifiche tecniche