

05301200 - LT-T BMT45 ER11F H44-100

Tipo	LT-T Portautensili tiltabile
Attacco	BMT 45
Uscita utensile	Portapinza ER 11 F
Raffreddamento	Refrigerazione esterna
Senso di rotazione	r1  r2 
Velocità max [1/min]	6000
Coppia max [Nm]	5
Rapporto	1:1
H [mm]	44-102
Accessori	N.D.
Note	N.D.
Note per il montaggio	N.D.

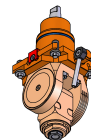

Verificare sempre gli ingombri del portautensile in torretta

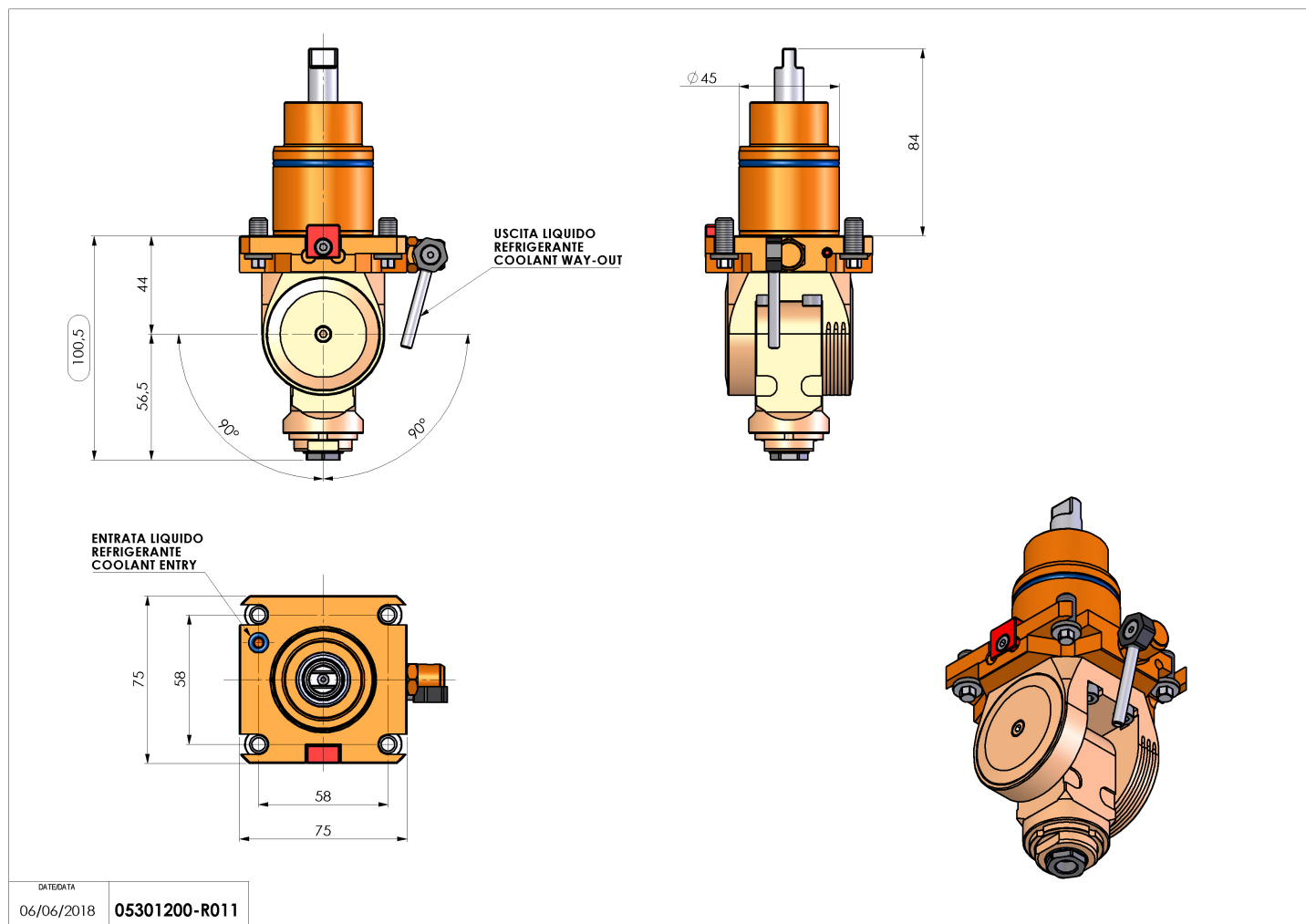

Salvo modifiche tecniche

DATE/DATE
06/06/2018 05301200-R011