

05250700 - LT-A VDI40 ER20F L H130 1:2 MZ

Tipo	LT-A Portautensili angolare a 90°
Attacco	VDI 40
Uscita utensile	Portapinza ER 20 F - ghiera interna
Raffreddamento	Refrigerazione esterna
Senso di rotazione	r1 r2
Velocità max [1/min]	in 5000 / out 10000
Coppia max [Nm]	in 50 / out 25
Rapporto	1:2
H [mm]	130
H1 [mm]	27
Accessori	N.D.
Note	N.D.
Note per il montaggio	Solo per mandrino principale

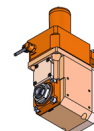

ATTENZIONE: VERIFICARE L'ORIENTAMENTO DELLA DENTATURA VDI

Verificare sempre gli ingombri del portautensile in torretta

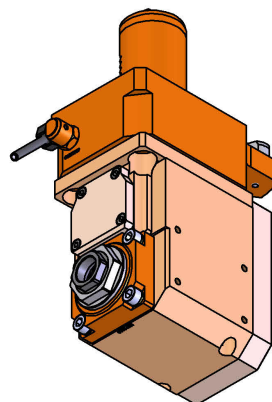
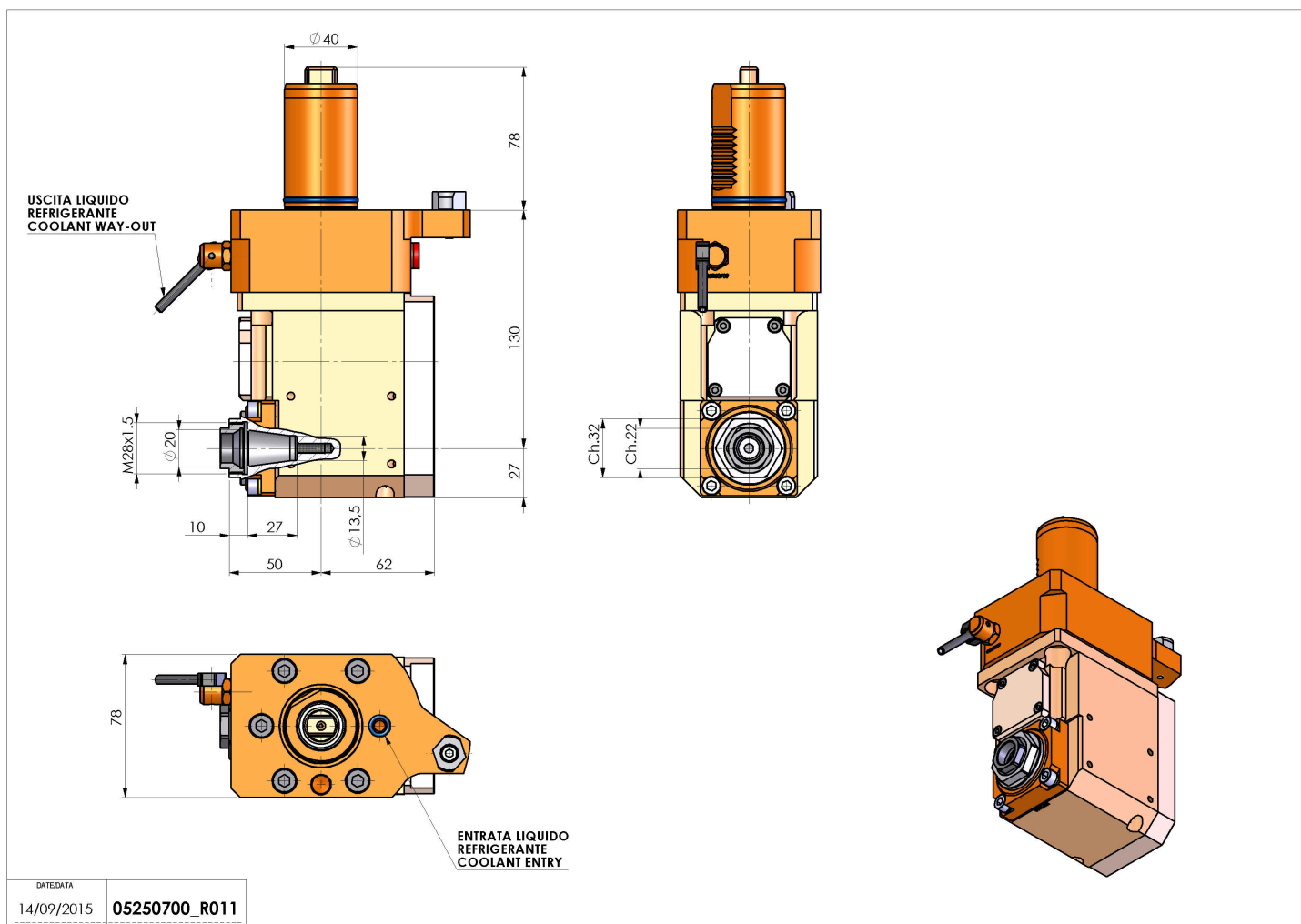

Salvo modifiche tecniche

DATE/ATA
14/09/2015 **05250700_R011**