

05192400 - LT-T VDI30 ER16FH63-132 1809DP

Tipo	LT-T Portautensili tiltabile
Attacco	VDI 30
Uscita utensile	Portapinza ER 16 F - ghiera interna
Raffreddamento	Refrigerazione esterna
Senso di rotazione	r1 r2
Velocità max [1/min]	6000
Coppia max [Nm]	10
Rapporto	1:1
H [mm]	63-132
Accessori	N.D.
Note	N.D.
Note per il montaggio	N.D.

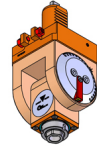

ATTENZIONE: VERIFICARE L'ORIENTAMENTO DELLA DENTATURA VDI

Verificare sempre gli ingombri del portautensile in torretta

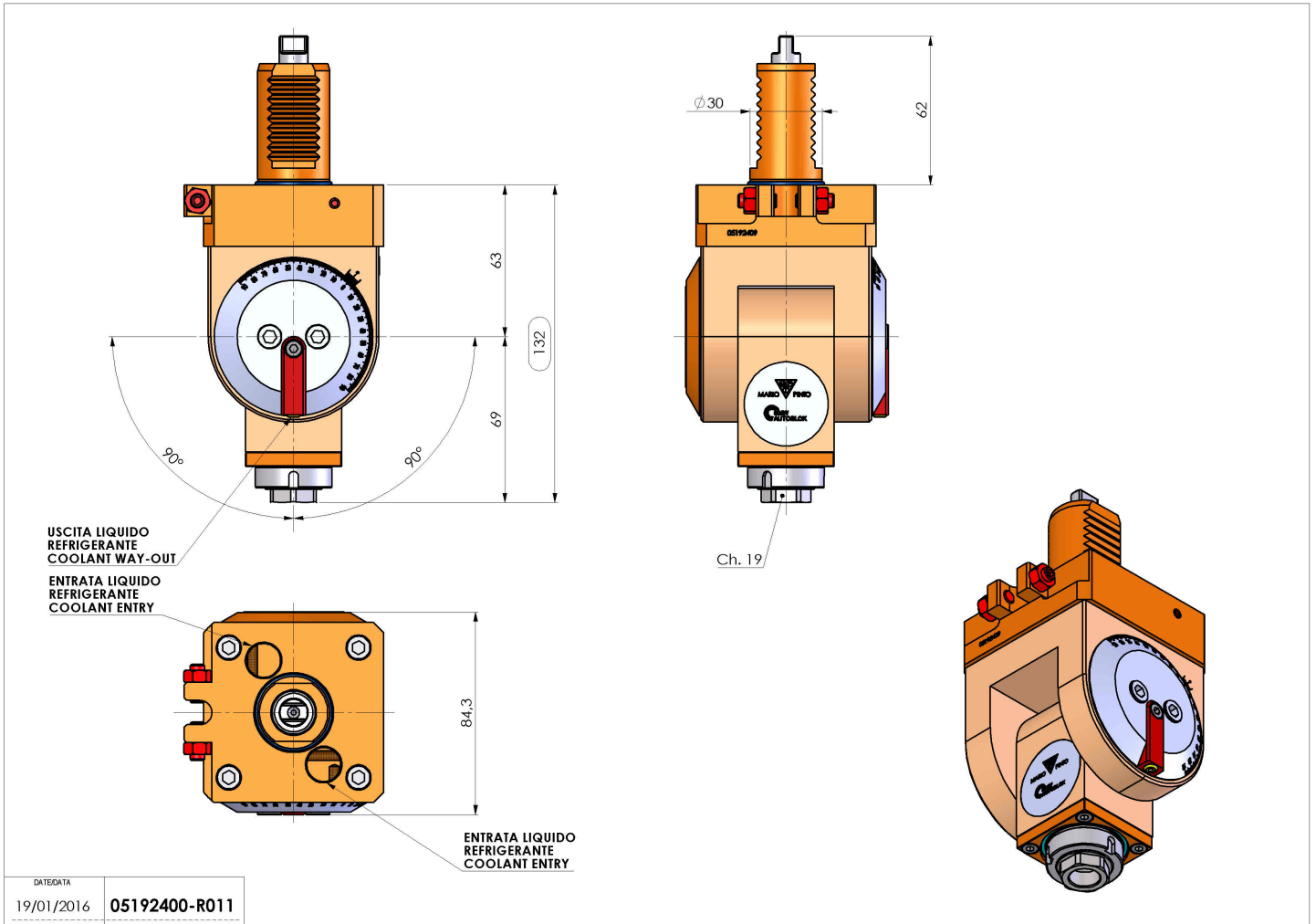

DATE/DATE: 19/01/2016
05192400-R011

Salvo modifiche tecniche