

05164200 - LT-S D40 ER25OF72LR HRF H108MU

Tipo	LT-S OFS Portautensili dritto offset
Attacco	CILINDRICO 40
Uscita utensile	Portapinza ER 25
Raffreddamento	Refrigerazione interna HRF
Offset [mm]	72
Senso di rotazione	r1 r2
Velocità max [1/min]	6000
Coppia max [Nm]	50
Rapporto	1:1
H [mm]	108.5
Pressione max [bar]	80
Accessori	Chiave albero, chiave ghiera, ghiera per pinze ER
Note	N.D.
Note per il montaggio	N.D.

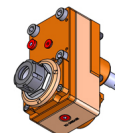

Verificare sempre gli ingombri del portautensile in torretta

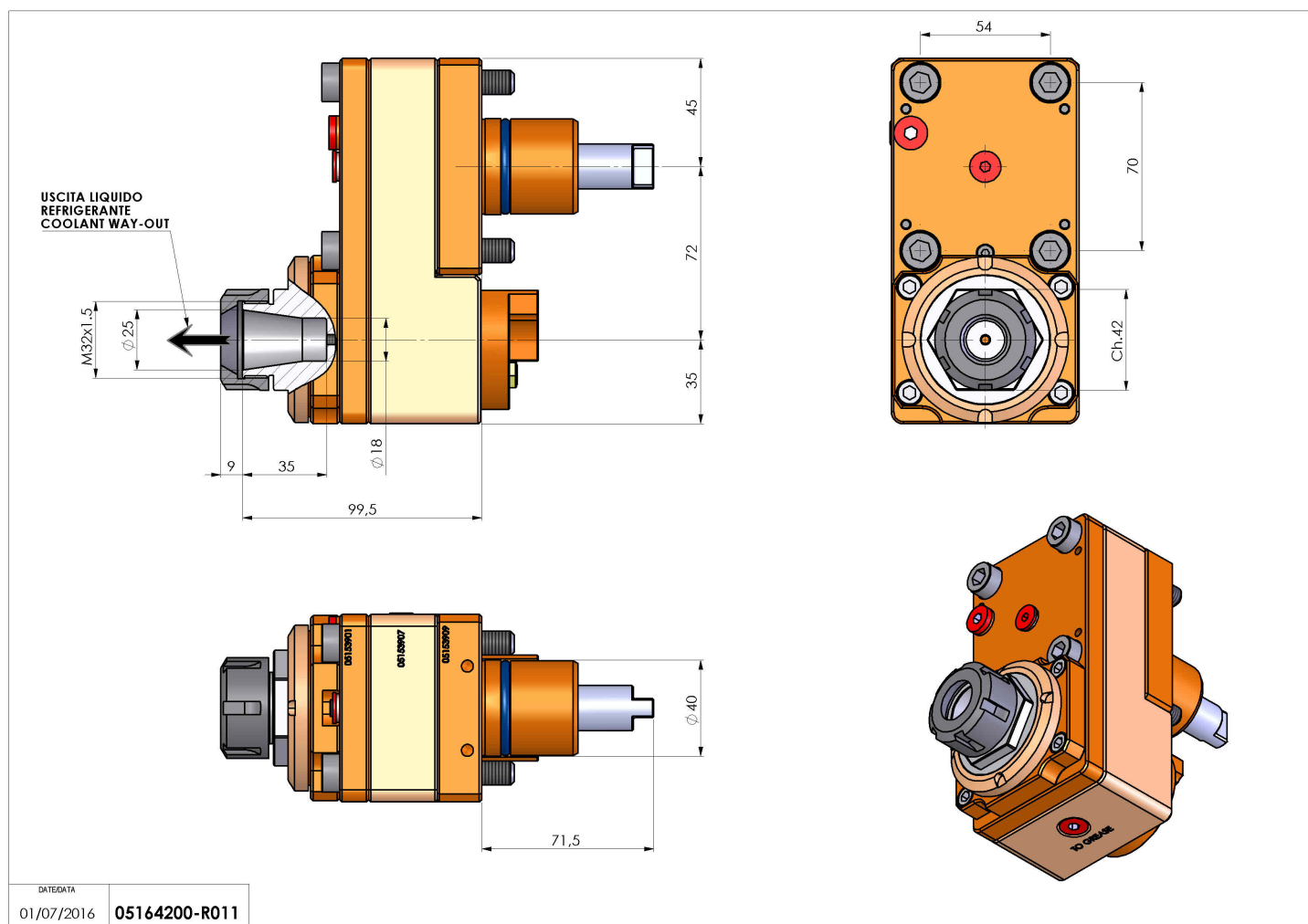

Salvo modifiche tecniche

DATE/DATE
01/07/2016 05164200-R011