

05161400 - LT-S D35ER20FOFS38.25 2:1H95MU

Tipo	LT-S OFS Portautensili dritto offset
Attacco	CILINDRICO 35
Uscita utensile	Portapinza ER 20 F - ghiera interna
Raffreddamento	Refrigerazione esterna
Offset [mm]	38,25
Senso di rotazione	r1 r2
Velocità max [1/min]	in 6000 / out 3000
Coppia max [Nm]	in 10 / out 20
Rapporto	2:1
H [mm]	95
Accessori	N.D.
Note	N.D.
Note per il montaggio	N.D.

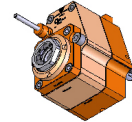

Verificare sempre gli ingombri del portautensile in torretta

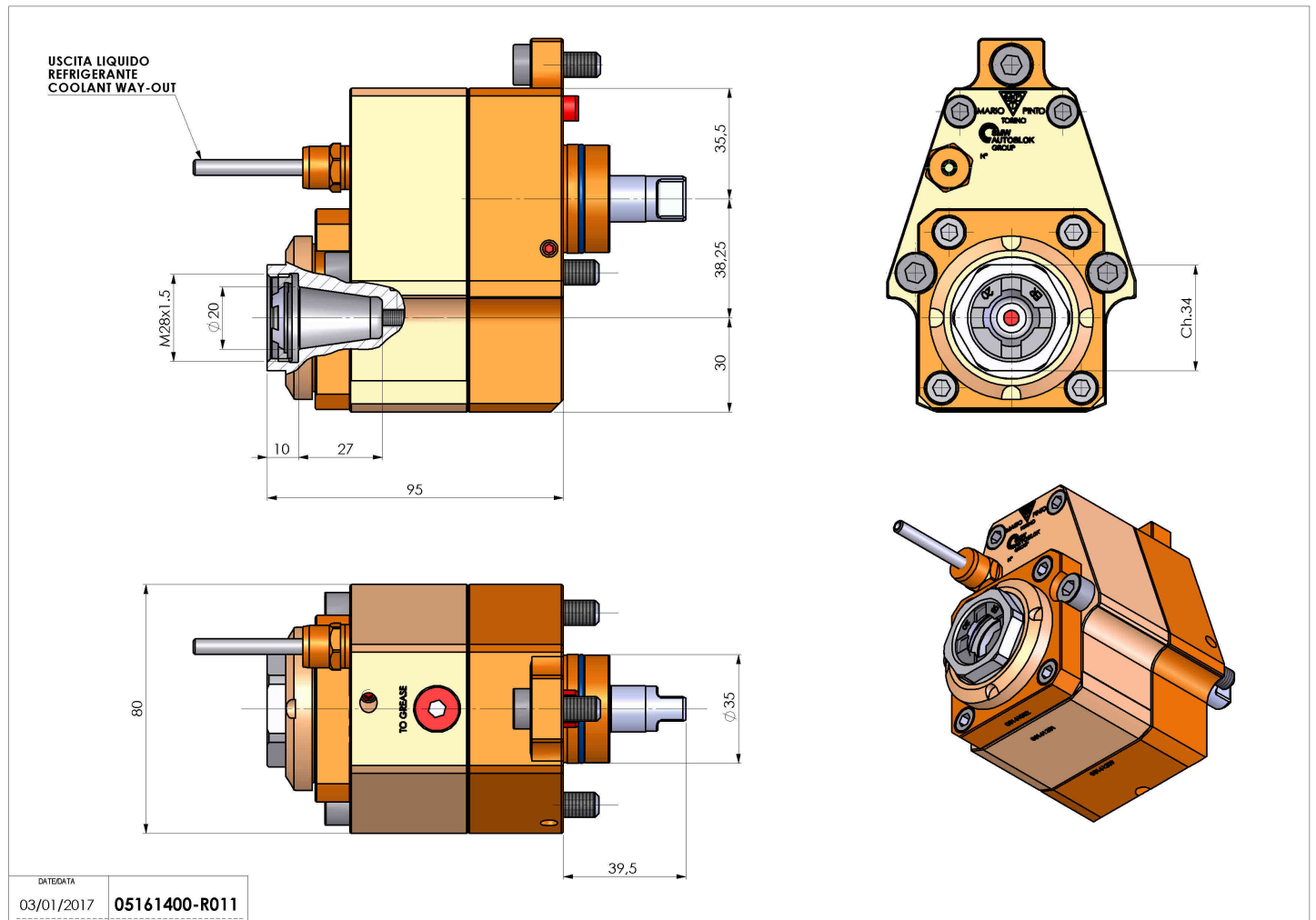

Salvo modifiche tecniche