



05153800 - LT-S D40 DIN138-22 H68 MU

Tipo	LT-S Portautensili dritto
Attacco	CILINDRICO 40
Uscita utensile	Portafresa DIN138 D22
Raffreddamento	Refrigerazione esterna
Senso di rotazione	r1  r2 
Velocità max [1/min]	6000
Coppia max [Nm]	40
Rapporto	1:1
H [mm]	68
Accessori	Chiave albero, chiave croce + gruppo accessori portafresa
Note	N.D.
Note per il montaggio	N.D.



Verificare sempre gli ingombri del portautensile in torretta

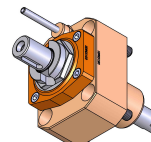
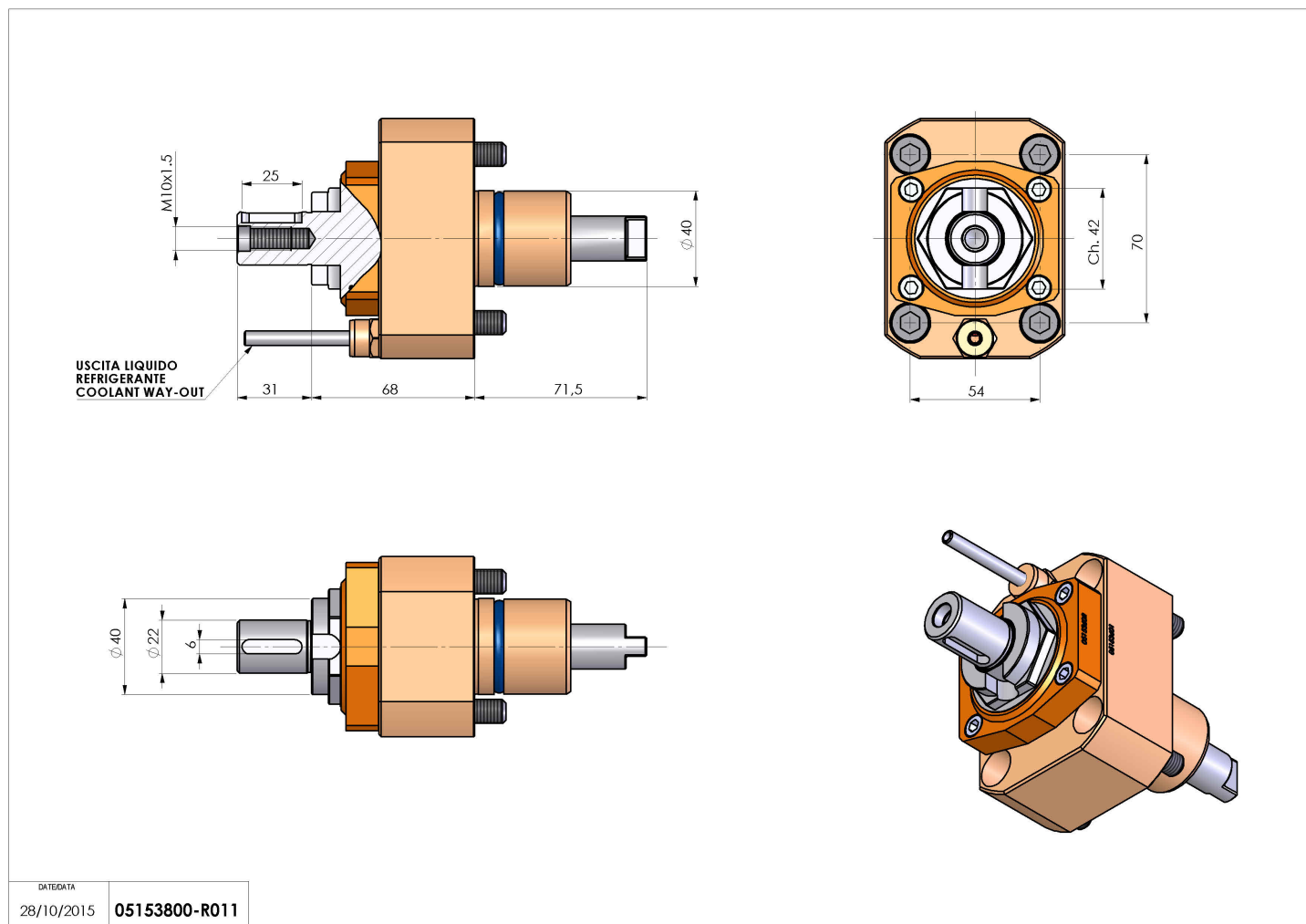

DATE/DATE	05153800-R011
28/10/2015	

Salvo modifiche tecniche