



## 05152000 - LT-SVDI40ER20FOF781:3KR HRFH90

<b>Tipo</b>	LT-S OFS Portautensili dritto offset
<b>Attacco</b>	VDI 40
<b>Uscita utensile</b>	Portapinza ER 20 F - ghiera interna
<b>Raffreddamento</b>	Refrigerazione interna HRF
<b>Offset [mm]</b>	78
<b>Senso di rotazione</b>	r1  r2 
<b>Velocità max [1/min]</b>	in 5000 / out 15000
<b>Coppia max [Nm]</b>	in 50 / out 14
<b>Rapporto</b>	1:3
<b>H [mm]</b>	89,5
<b>Pressione max [bar]</b>	80
<b>Accessori</b>	N.D.
<b>Note</b>	N.D.
<b>Note per il montaggio</b>	N.D.

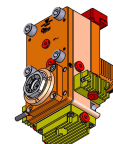

### ATTENZIONE: VERIFICARE L'ORIENTAMENTO DELLA DENTATURA VDI

Verificare sempre gli ingombri del portautensile in torretta

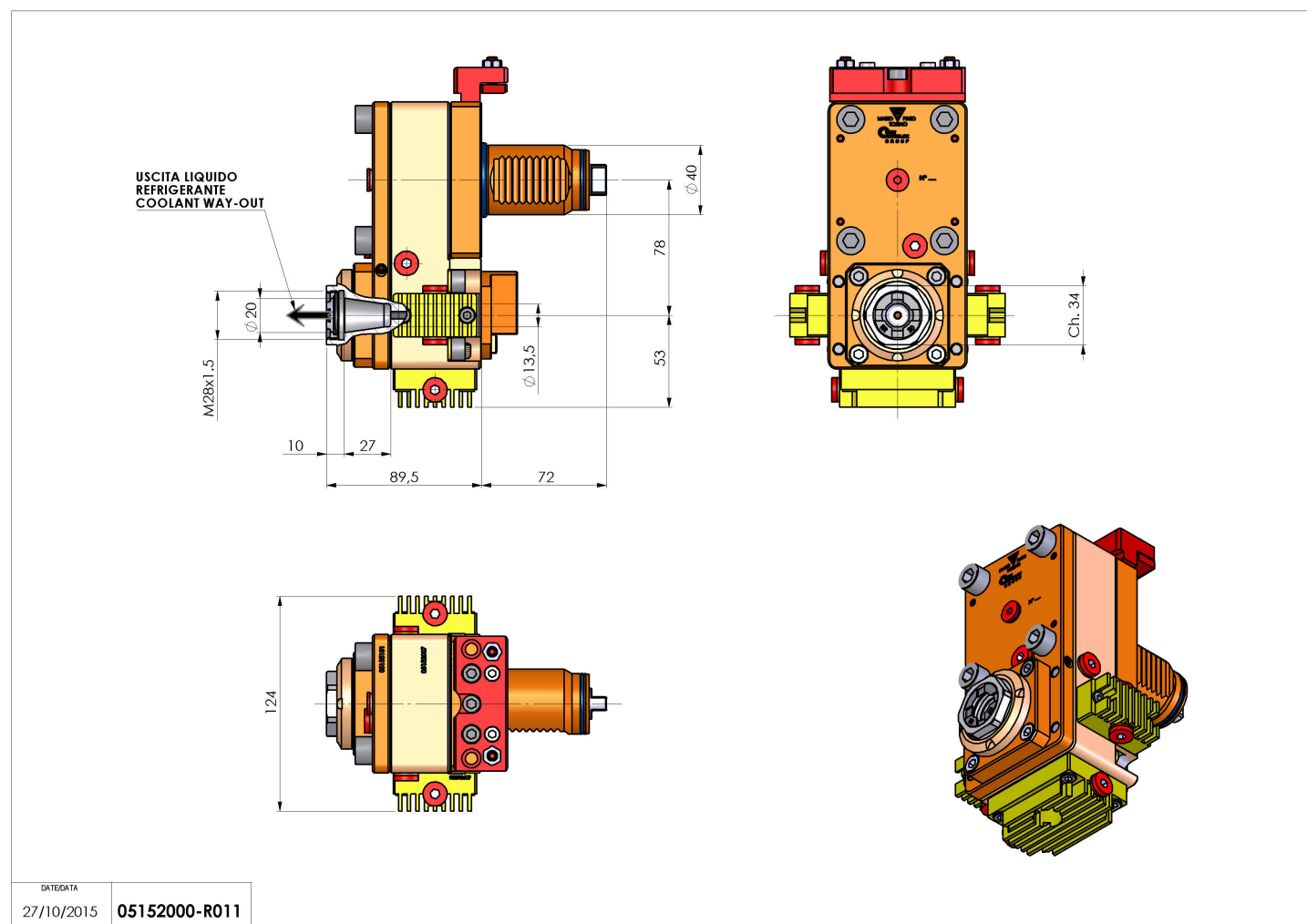

DATE/ATA	05152000-R011
27/10/2015	

Salvo modifiche tecniche