



05126100 - LT-S BMT45 ER20F RF H51 DW

Tipo	LT-S Portautensili dritto
Attacco	BMT 45
Uscita utensile	Portapinza ER 20 F - ghiera interna
Raffreddamento	Refrigerazione interna
Senso di rotazione	r1  r2 
Velocità max [1/min]	6000
Coppia max [Nm]	25
Rapporto	1:1
H [mm]	50,5
Pressione max [bar]	20
Accessori	Chiave albero, chiave ghiera, ghiera per pinze ER
Note	N.D.
Note per il montaggio	N.D.



Verificare sempre gli ingombri del portautensile in torretta

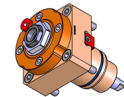
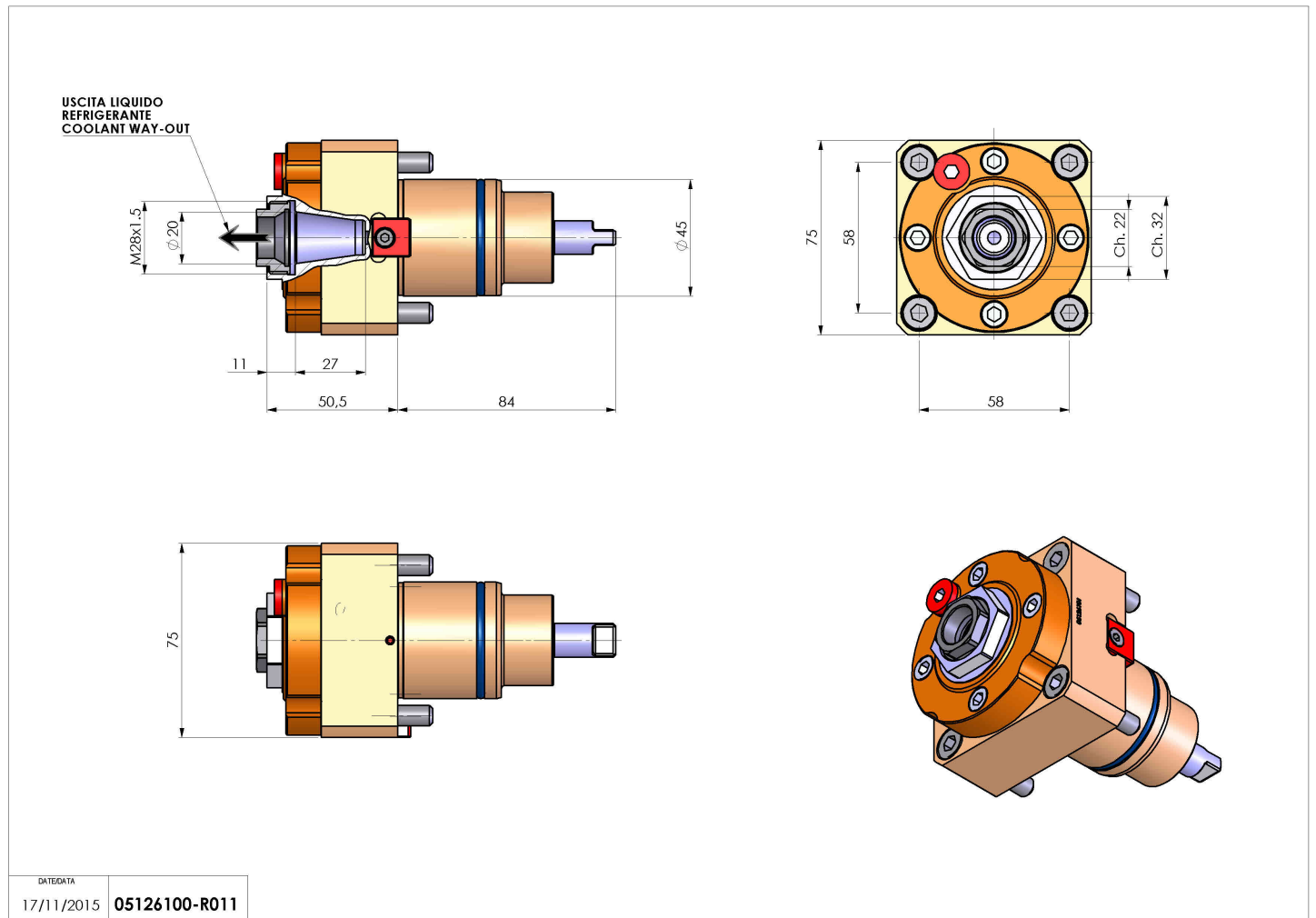

Salvo modifiche tecniche

DATE/ATA
 17/11/2015 05126100-R011