



05061800 - LT-A VDI40 ER32F-32F H90 OK

Tipo	LT-A DBL Portautensili angolare doppio a 90°
Attacco	VDI 40
Uscita utensile	Portapinza ER 32 F - ghiera interna
Raffreddamento	Refrigerazione esterna
Senso di rotazione	r1  r2  r3 
Velocità max [1/min]	6000
Coppia max [Nm]	63
Rapporto	1:1
H [mm]	90
H1 [mm]	37,5
Accessori	N.D.
Note	N.D.
Note per il montaggio	Solo per mandrino principale

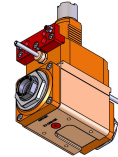

ATTENZIONE: VERIFICARE L'ORIENTAMENTO DELLA DENTATURA VDI

Verificare sempre gli ingombri del portautensile in torretta

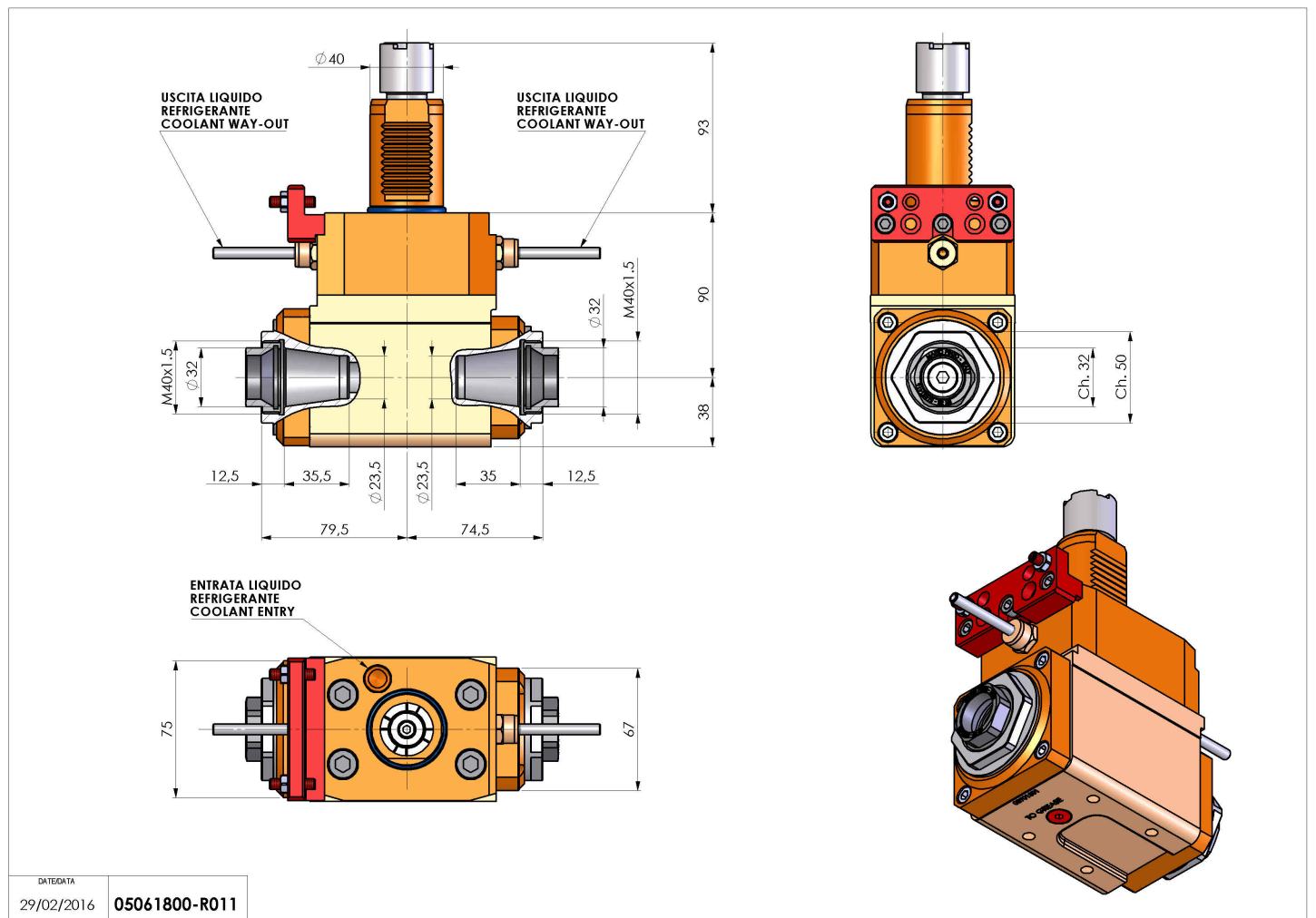

DATE/GRA
29/02/2016 05061800-R011

Salvo modifiche tecniche