

05056000 - SUPP ALB AX 20-100MZ INTGRX

Tipo	SHAFT SUPPORT Supporto alberi
Attacco	MAZAK
Uscita utensile	Supporto albero Ø20-Ø100
Raffreddamento	N.D.
H [mm]	70,5
Ø Min [mm]	20
Ø Max [mm]	100
Accessori	N.D.
Note	N.D.
Note per il montaggio	N.D.

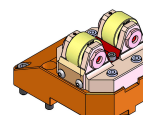

Verificare sempre gli ingombri del portautensile in torretta

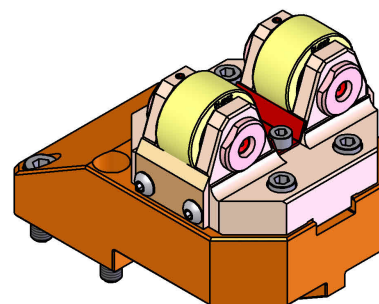
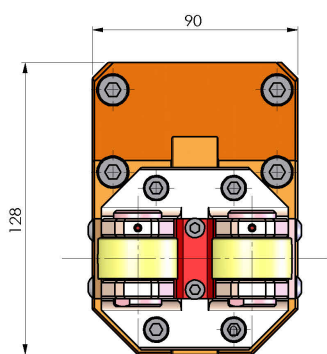
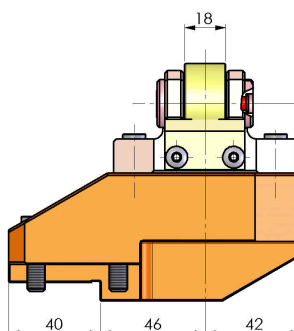
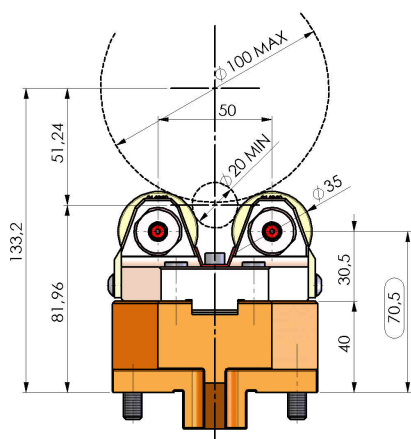

DATE/ATA
04/09/2015 05056000-R011

Salvo modifiche tecniche