

# 05016800 - LT-S2 D55 ER16F-16F 1:1 H75 NK

<b>Tipo</b>	LT-S2 Portautensili dritto doppio
<b>Attacco</b>	CILINDRICO 55
<b>Uscita utensile</b>	Portapinza ER 16 F - ghiera interna
<b>Raffreddamento</b>	Refrigerazione esterna
<b>Senso di rotazione</b>	r1 ↻ r2 ↻ r3 ↻
<b>Velocità max [1/min]</b>	6000
<b>Coppia max [Nm]</b>	15
<b>Rapporto</b>	1:1
<b>H [mm]</b>	75
<b>Accessori</b>	N.D.
<b>Note</b>	N.D.
<b>Note per il montaggio</b>	N.D.

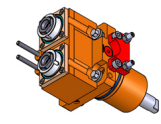

Verificare sempre gli ingombri del portautensile in torretta

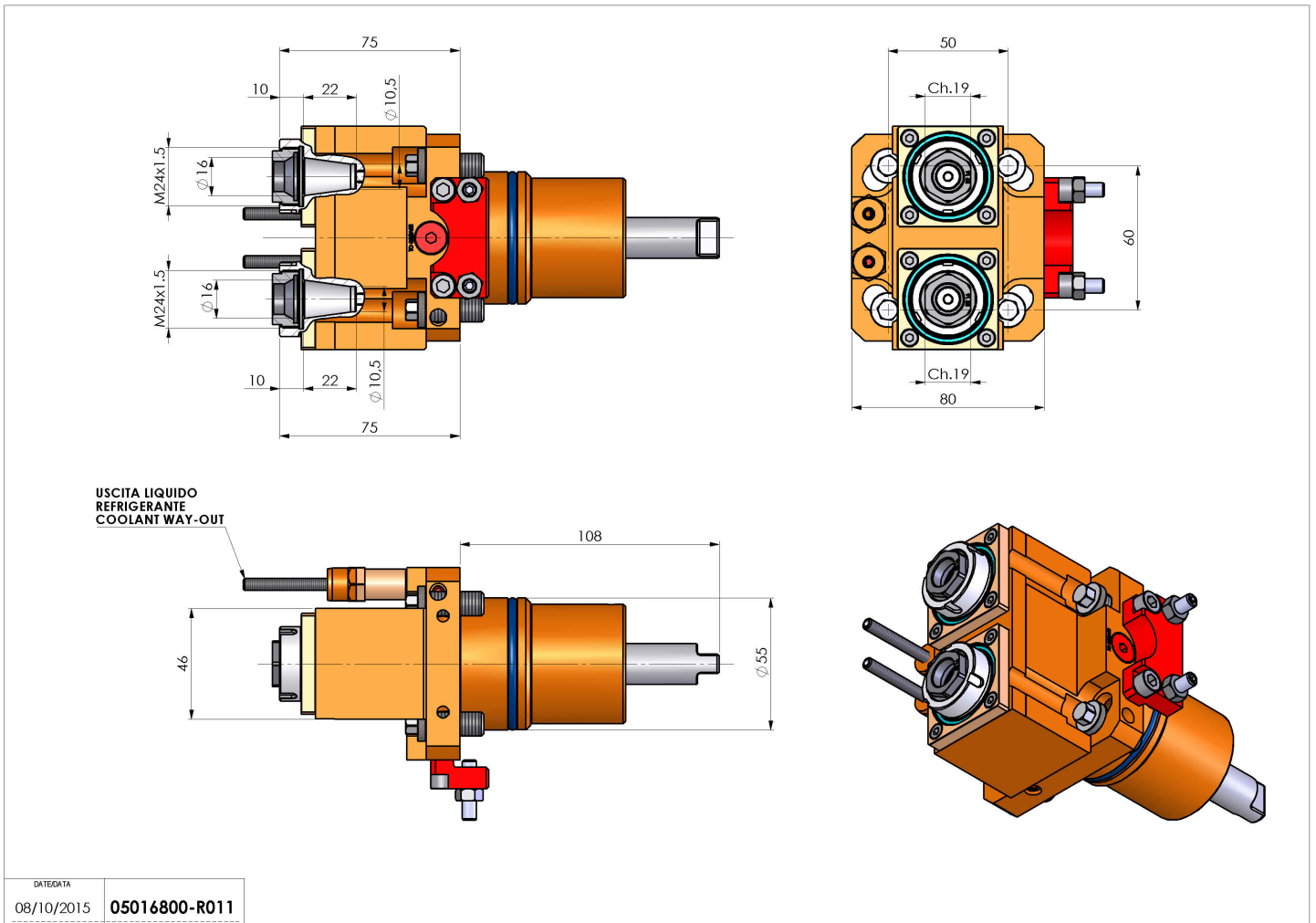

Salvo modifiche tecniche

DATE/DATE	08/10/2015	05016800-R011
-----------	------------	---------------