

# 05482700 - LT-A VDI40 ER32F HRF H100 FA

<b>Tipo</b>	LT-A Portautensili angolare a 90°
<b>Attacco</b>	VDI 40
<b>Uscita utensile</b>	Portapinza ER 32 F - ghiera interna
<b>Raffreddamento</b>	Refrigerazione interna HRF
<b>Senso di rotazione</b>	r1 ↻ r2 ↻
<b>Velocità max [1/min]</b>	8000
<b>Coppia max [Nm]</b>	80
<b>Rapporto</b>	1:1
<b>H [mm]</b>	100
<b>H1 [mm]</b>	38
<b>Pressione max [bar]</b>	80
<b>Accessori</b>	N.D.
<b>Note</b>	N.D.
<b>Note per il montaggio</b>	N.D.

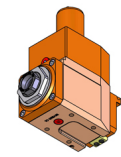

**ATTENZIONE: VERIFICARE L'ORIENTAMENTO DELLA DENTATURA VDI**

Verificare sempre gli ingombri del portautensile in torretta

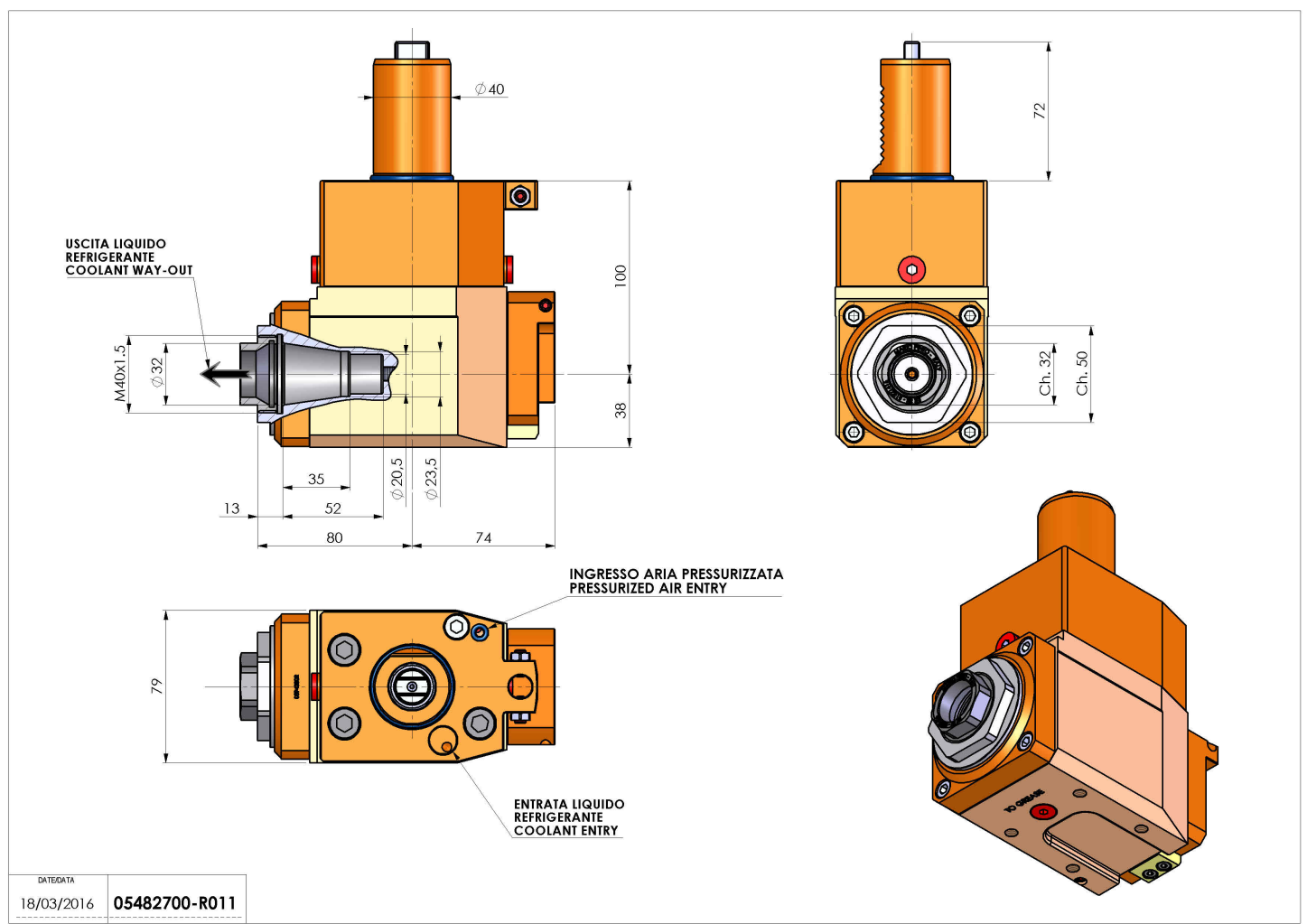

DATE/GATA	18/03/2016	05482700-R011
-----------	------------	---------------

Salvo modifiche tecniche