

## 05450100 - LT-A D68 ER32F-32F HS H80

<b>Tipo</b>	LT-A DBL Portautensili angolare doppio a 90°
<b>Attacco</b>	CILINDRICO 68
<b>Uscita utensile</b>	Portapinza ER 32 F - ghiera interna
<b>Raffreddamento</b>	Refrigerazione esterna
<b>Senso di rotazione</b>	r1 ↻ r2 ↻ r3 ↻
<b>Velocità max [1/min]</b>	10000
<b>Coppia max [Nm]</b>	63
<b>Rapporto</b>	1:1
<b>H [mm]</b>	80
<b>H1 [mm]</b>	38
<b>Accessori</b>	N.D.
<b>Note</b>	Sostituito da cod. 05450400
<b>Note per il montaggio</b>	Solo per mandrino principale

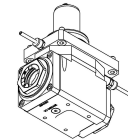

REPLACED BY 05450400

Verificare sempre gli ingombri del portautensile in torretta

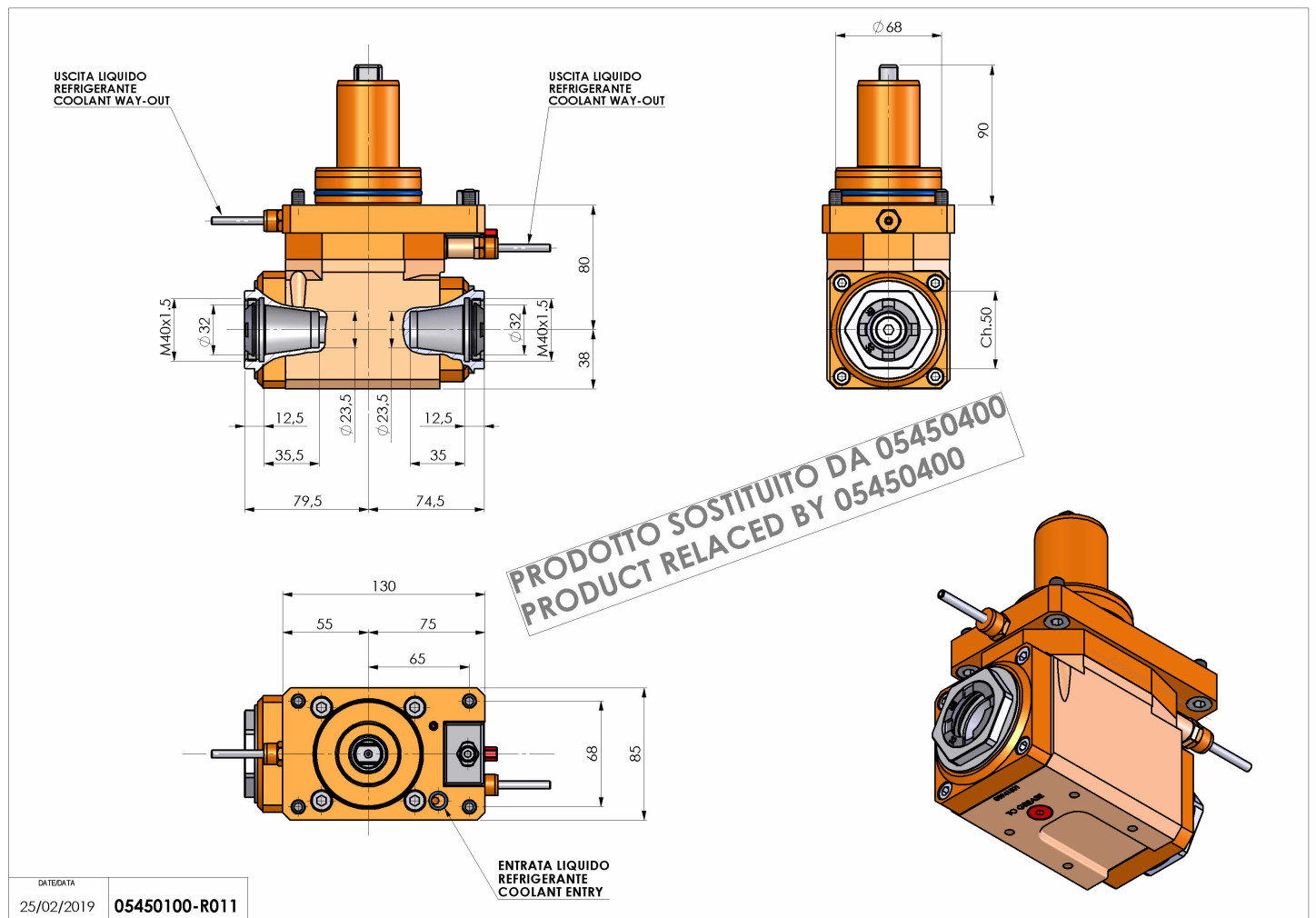

Salvo modifiche tecniche