



05320200 - LT-S BMT75 ER32F OF51RF1:2H110

Tipo	LT-S OFS Portautensili dritto offset
Attacco	BMT 75
Uscita utensile	Portapinza ER 32 F - ghiera interna
Raffreddamento	Refrigerazione interna
Offset [mm]	51
Senso di rotazione	r1  r2 
Velocità max [1/min]	in 4000 / out 8000
Coppia max [Nm]	in 50 / out 25
Rapporto	1:2
H [mm]	110
Pressione max [bar]	20
Accessori	N.D.
Note	N.D.
Note per il montaggio	N.D.



Verificare sempre gli ingombri del portautensile in torretta

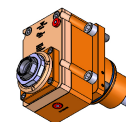
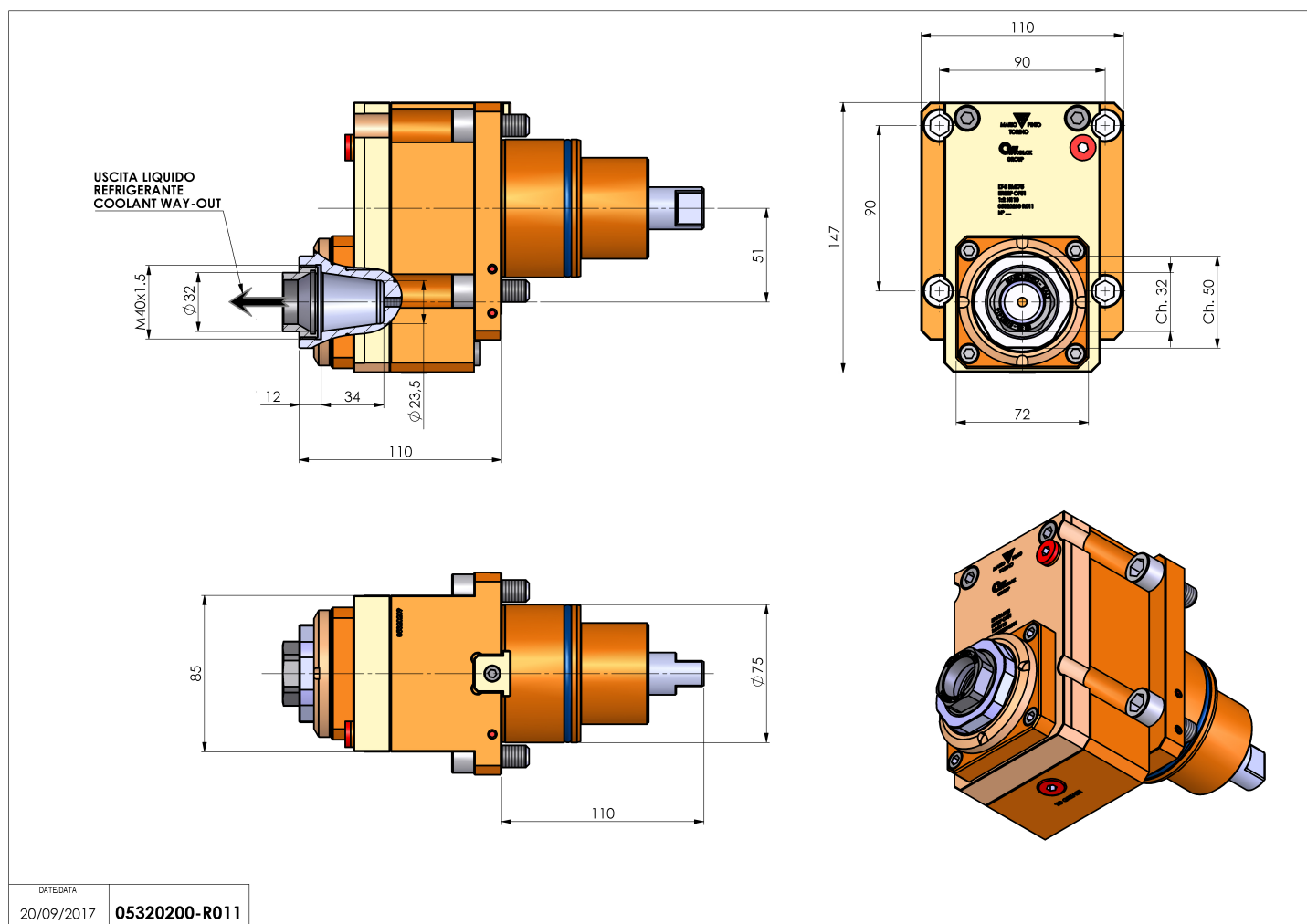

Salvo modifiche tecniche