



05315100 - LT-A BMT75 BD ER40F LR RF H90

Tipo	LT-A Portautensili angolare a 90°
Attacco	BMT 75 BIG DRIVE
Uscita utensile	Portapinza ER 40 F - ghiera interna
Raffreddamento	Refrigerazione interna
Senso di rotazione	r1  r2 
Velocità max [1/min]	4000
Coppia max [Nm]	80
Rapporto	1:1
H [mm]	90
H1 [mm]	43
Pressione max [bar]	20
Accessori	N.D.
Note	N.D.
Note per il montaggio	Mandrino principale e secondario



Verificare sempre gli ingombri del portautensile in torretta

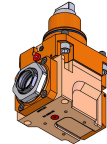
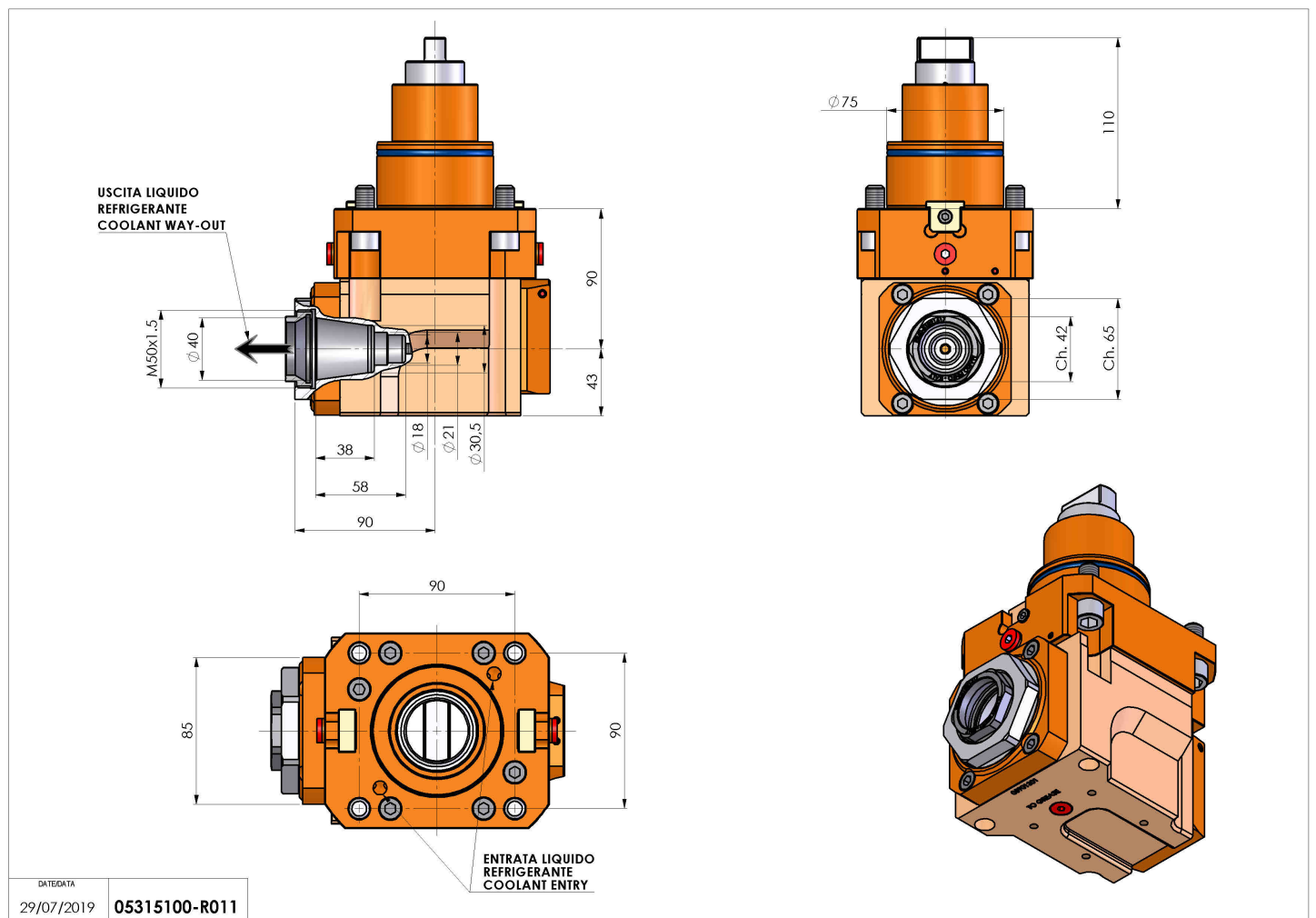

Salvo modifiche tecniche