



05309300 - LT-S BMT45 ER25F H61

Tipo	LT-S Portautensili dritto
Attacco	BMT 45
Uscita utensile	Portapinza ER 25 F - ghiera interna
Raffreddamento	Refrigerazione esterna
Senso di rotazione	r1  r2 
Velocità max [1/min]	6000
Coppia max [Nm]	25
Rapporto	1:1
H [mm]	61
Accessori	N.D.
Note	N.D.
Note per il montaggio	N.D.



Verificare sempre gli ingombri del portautensile in torretta

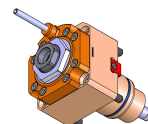
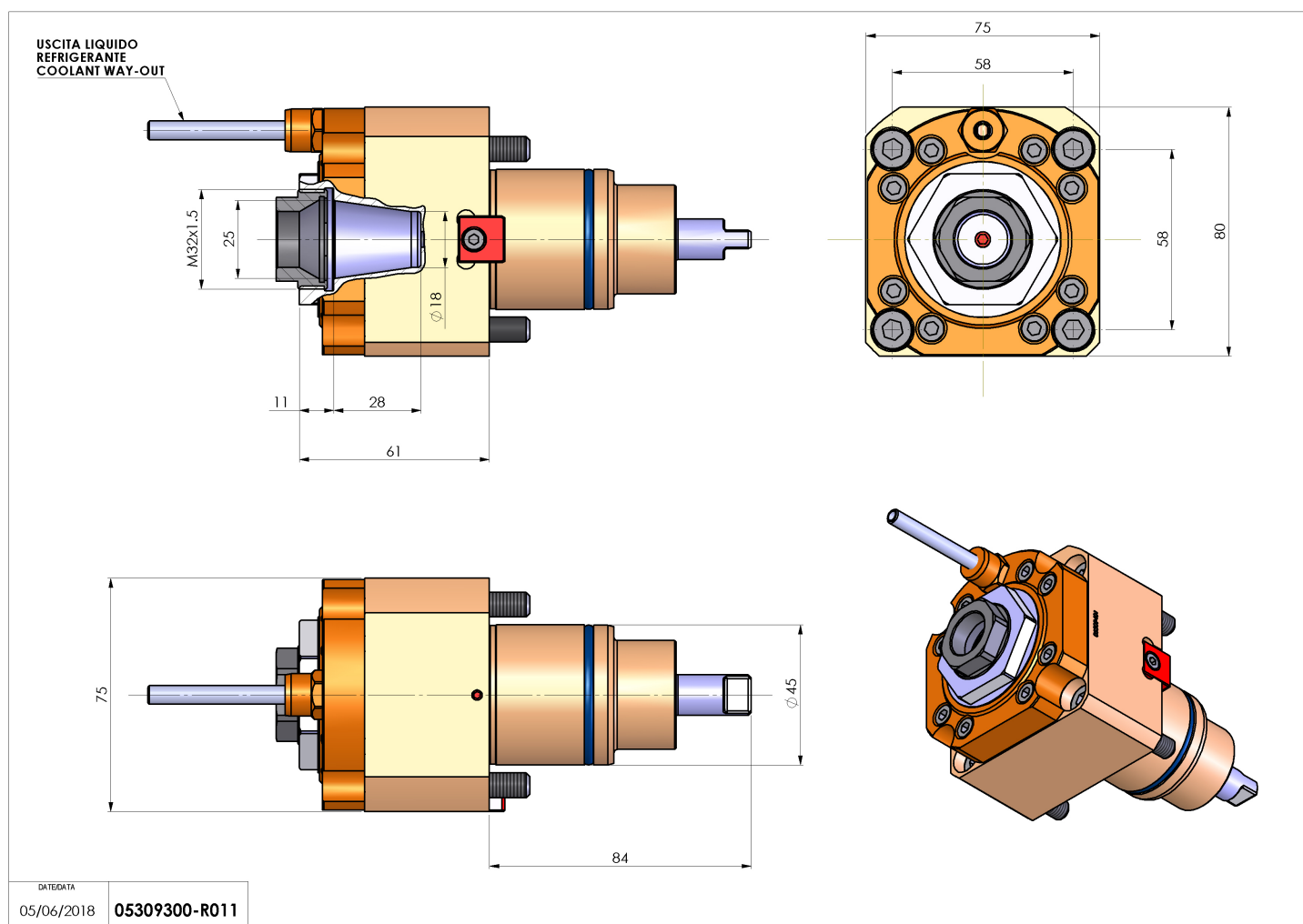

Salvo modifiche tecniche