

05308800 - LT-A BMT45 ER25F LR RF H85

Tipo	LT-A Portautensili angolare a 90°
Attacco	BMT 45
Uscita utensile	Portapinza ER 25 F - ghiera interna
Raffreddamento	Refrigerazione interna
Senso di rotazione	r1 r2
Velocità max [1/min]	6000
Coppia max [Nm]	30
Rapporto	1:1
H [mm]	85
H1 [mm]	32.5
Pressione max [bar]	20
Accessori	N.D.
Note	N.D.
Note per il montaggio	Mandrino principale e secondario

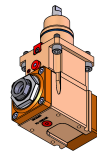

Verificare sempre gli ingombri del portautensile in torretta

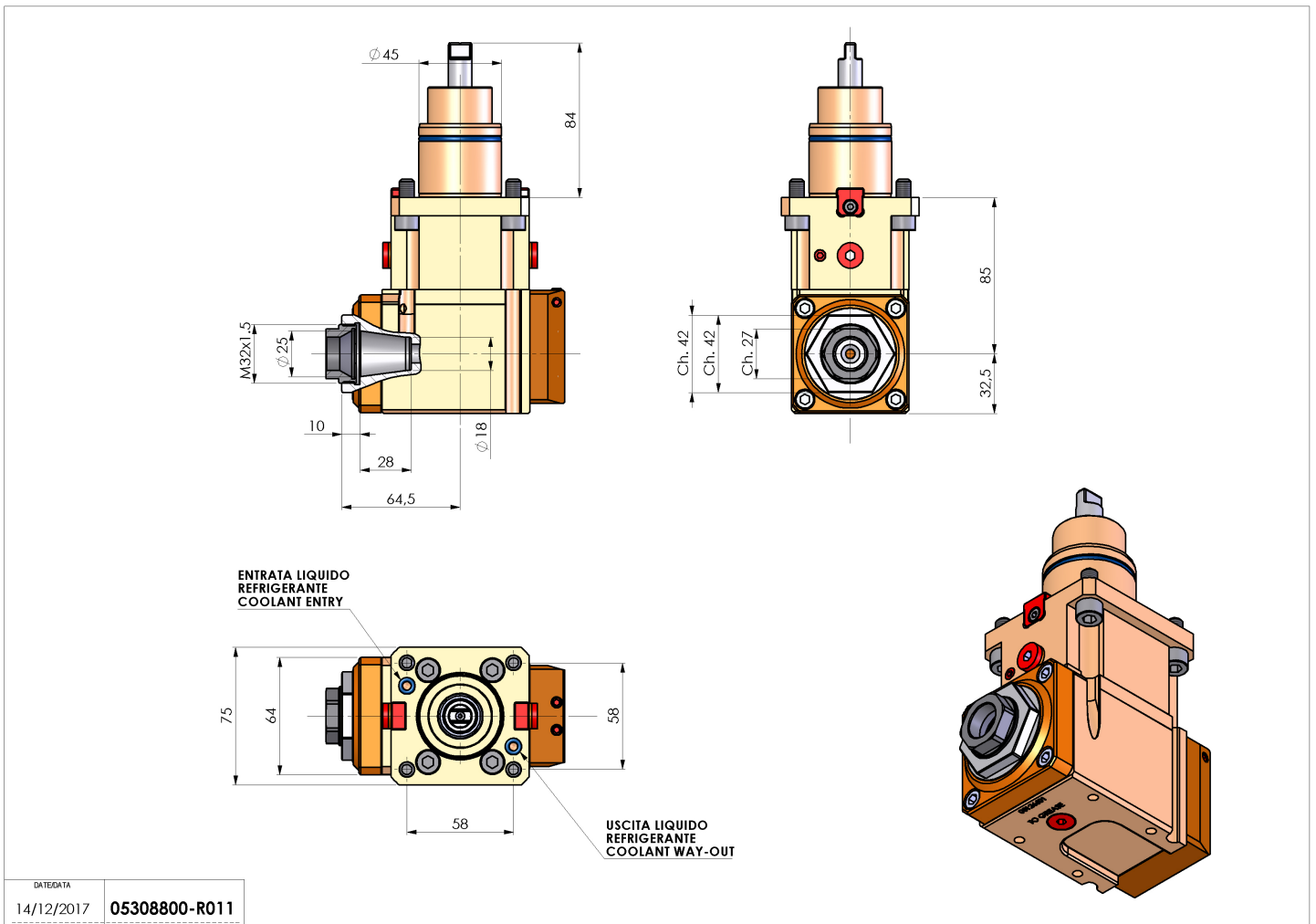

DATA	05308800-R011
14/12/2017	

Salvo modifiche tecniche