

## 05300200 - LT-S BMT45 P-FR D16 H122.25

<b>Tipo</b>	LT-S Portautensili dritto
<b>Attacco</b>	BMT 45
<b>Uscita utensile</b>	Diametro utensile 16
<b>Raffreddamento</b>	Refrigerazione esterna
<b>Senso di rotazione</b>	r1  r2
<b>Velocità max [1/min]</b>	6000
<b>Coppia max [Nm]</b>	25
<b>Rapporto</b>	1:1
<b>H [mm]</b>	122,25
<b>Accessori</b>	Chiave albero, gruppo accessori portafresa
<b>Note</b>	N.D.
<b>Note per il montaggio</b>	N.D.

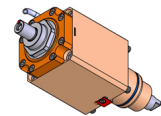

Verificare sempre gli ingombri del portautensile in torretta

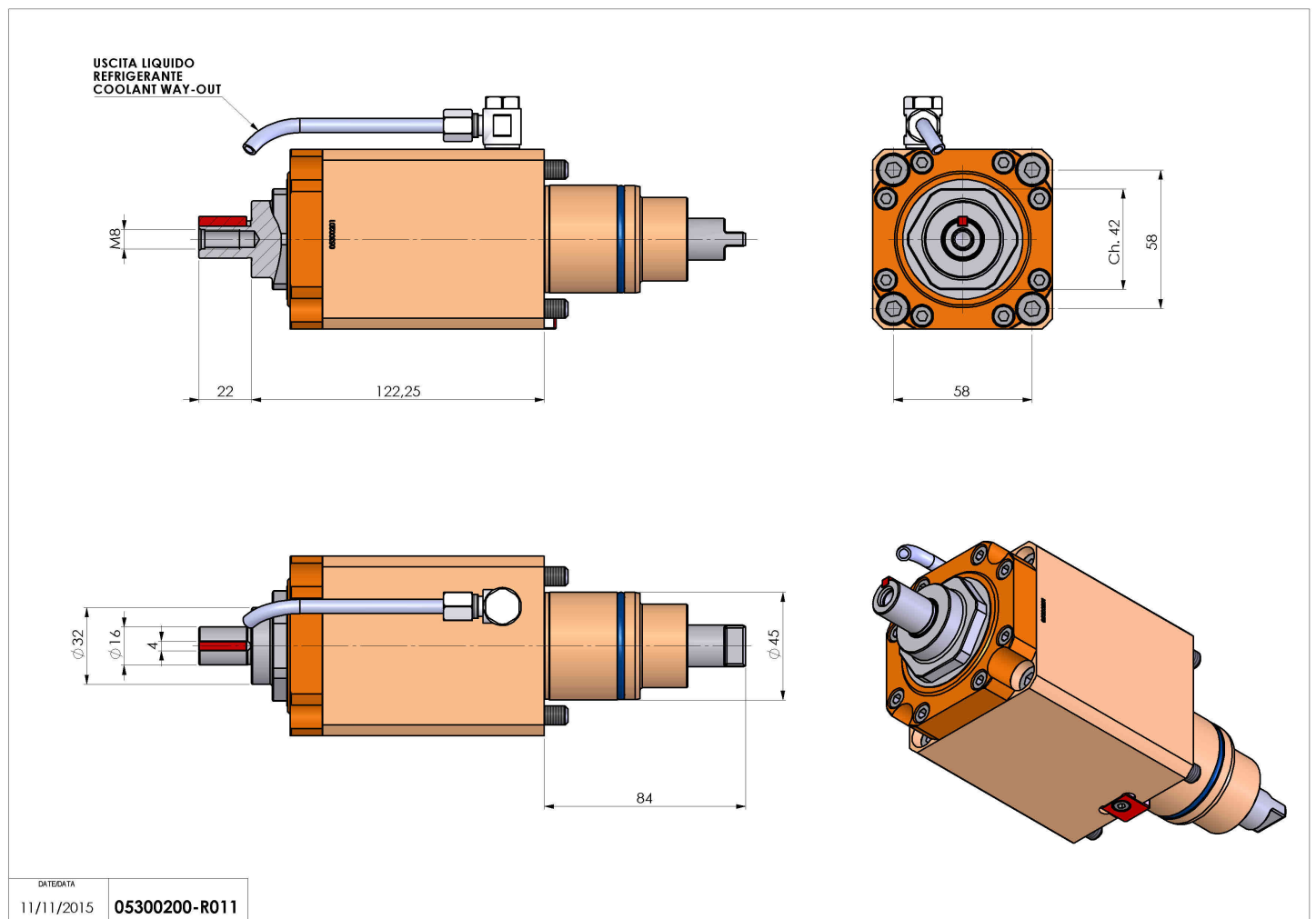

DATE/DATE	
11/11/2015	<b>05300200-R011</b>

Salvo modifiche tecniche