



05257800 - LT-A VDI50 ER40F-40F L H160 MZ

Tipo	LT-A DBL Portautensili angolare doppio a 90°
Attacco	VDI 50
Uscita utensile	Portapinza ER 40 F - ghiera interna
Raffreddamento	Refrigerazione esterna
Senso di rotazione	r1  r2  r3 
Velocità max [1/min]	6000
Coppia max [Nm]	80
Rapporto	1:1
H [mm]	160
H1 [mm]	43
Accessori	N.D.
Note	N.D.
Note per il montaggio	N.D.

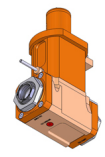

ATTENZIONE: VERIFICARE L'ORIENTAMENTO DELLA DENTATURA VDI

Verificare sempre gli ingombri del portautensile in torretta

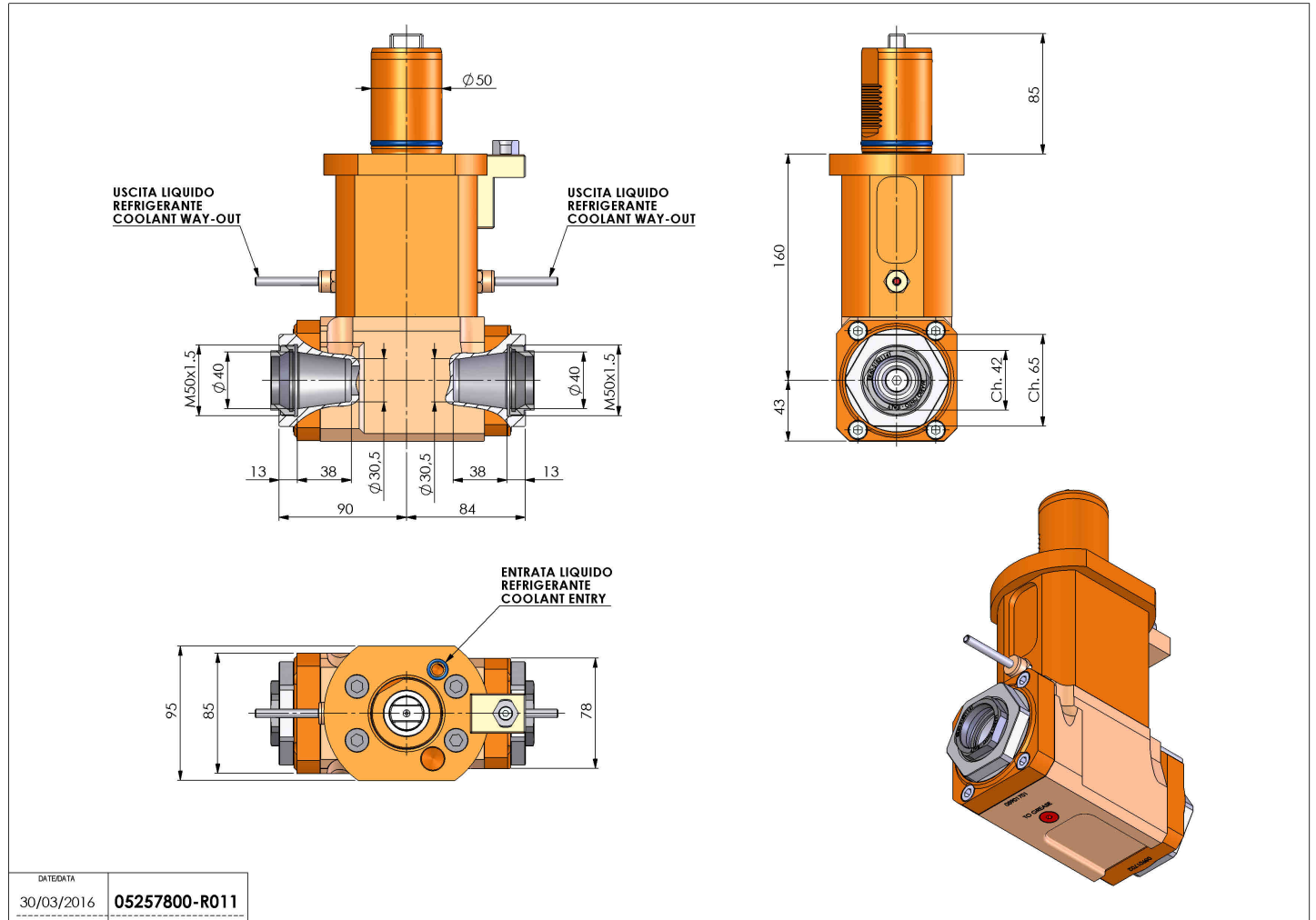

DATE/DATE	05257800-R011
30/03/2016	

Salvo modifiche tecniche