

05240300 - LT-A2V D60 ER20-20 LR OFS63

Tipo	LT-A2 V Portautensili angolare a 90° doppio verticale
Attacco	CILINDRICO 60
Uscita utensile	Portapinza ER 20
Raffreddamento	Refrigerazione esterna
Offset [mm]	63
Senso di rotazione	r1 r2 r3
Velocità max [1/min]	6000
Coppia max [Nm]	25
Rapporto	1:1
H [mm]	59.5-122,5
H1 [mm]	27
Accessori	N.D.
Note	N.D.
Note per il montaggio	N.D.

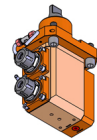

Verificare sempre gli ingombri del portautensile in torretta

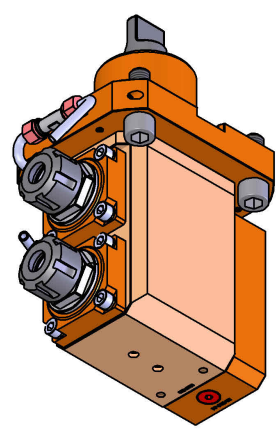
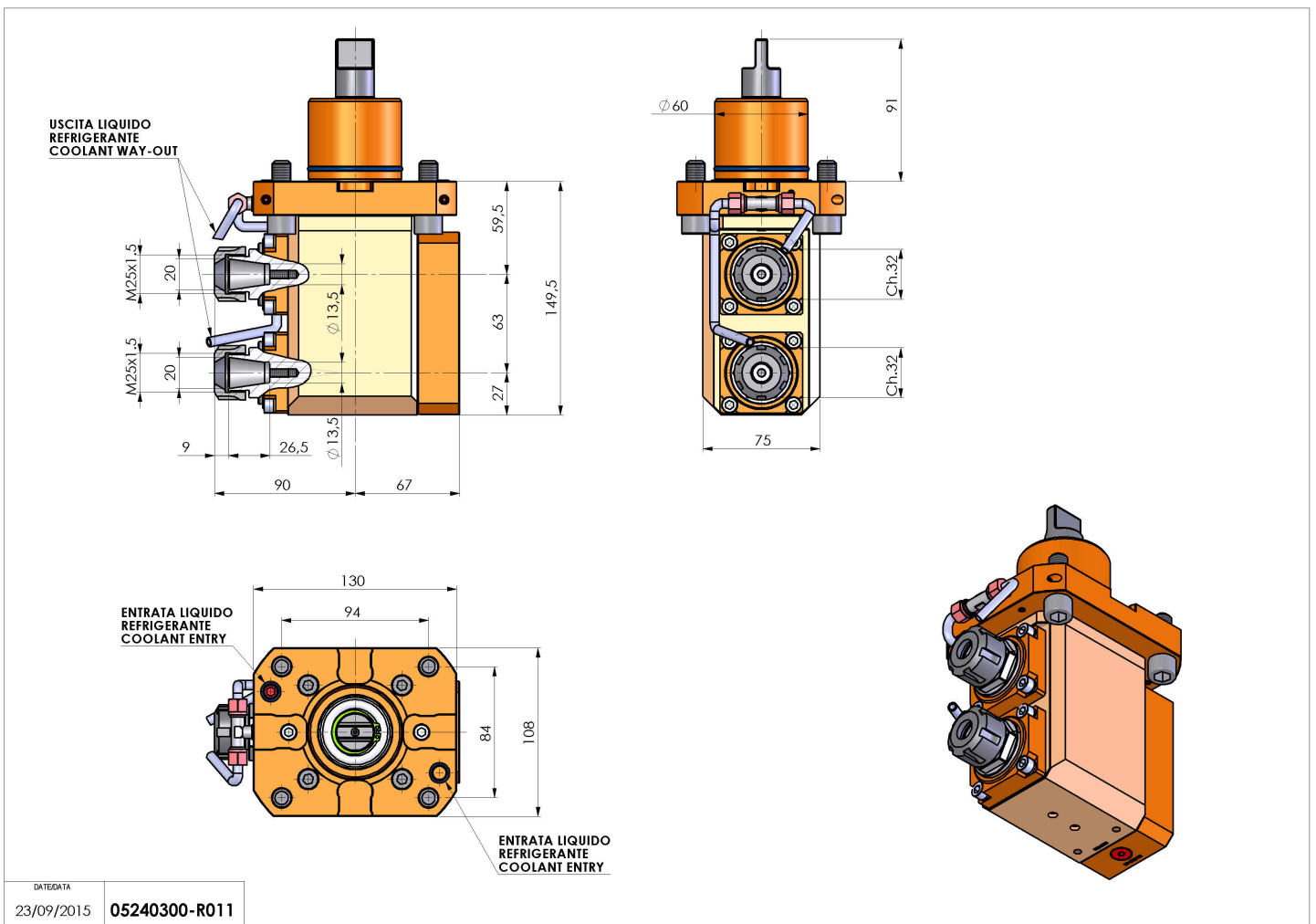

DATE/DATE	
23/09/2015	05240300-R011

Salvo modifiche tecniche