



05168100 - LT-A D35 ER20F 2:1 H60

Tipo	LT-A Portautensili angolare a 90°
Attacco	CILINDRICO 35
Uscita utensile	Portapinza ER 20 F - ghiera interna
Raffreddamento	Refrigerazione esterna
Senso di rotazione	r1  r2 
Velocità max [1/min]	in 6000 / out 3000
Coppia max [Nm]	in 10 / out 20
Rapporto	2:1
H [mm]	60
H1 [mm]	28
Accessori	N.D.
Note	N.D.
Note per il montaggio	N.D.



Verificare sempre gli ingombri del portautensile in torretta

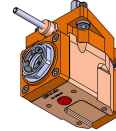
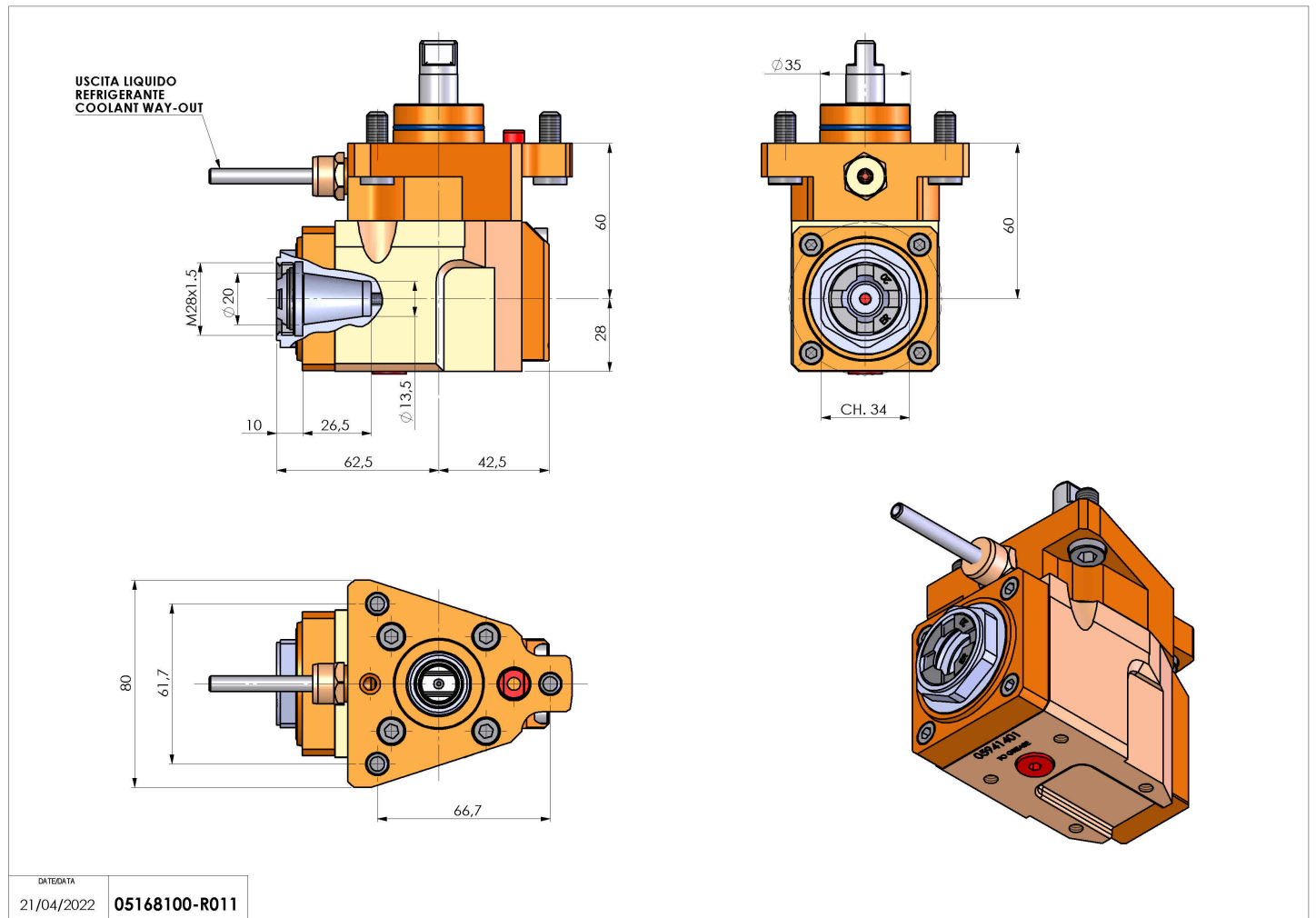

DATE/DATE
21/04/2022 05168100-R011

Salvo modifiche tecniche