

## 05163400 - LT-A D40 ER32F L-R H100 MU

<b>Tipo</b>	LT-A Portautensili angolare a 90°
<b>Attacco</b>	CILINDRICO 40
<b>Uscita utensile</b>	Portapinza ER 32 F - ghiera interna
<b>Raffreddamento</b>	Refrigerazione esterna
<b>Senso di rotazione</b>	r1 ↻ r2 ↻
<b>Velocità max [1/min]</b>	6000
<b>Coppia max [Nm]</b>	63
<b>Rapporto</b>	1:1
<b>H [mm]</b>	100
<b>H1 [mm]</b>	36
<b>Accessori</b>	N.D.
<b>Note</b>	N.D.
<b>Note per il montaggio</b>	N.D.

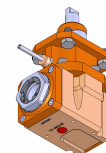

Verificare sempre gli ingombri del portautensile in torretta

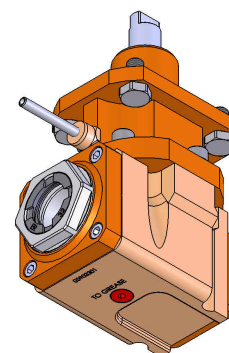
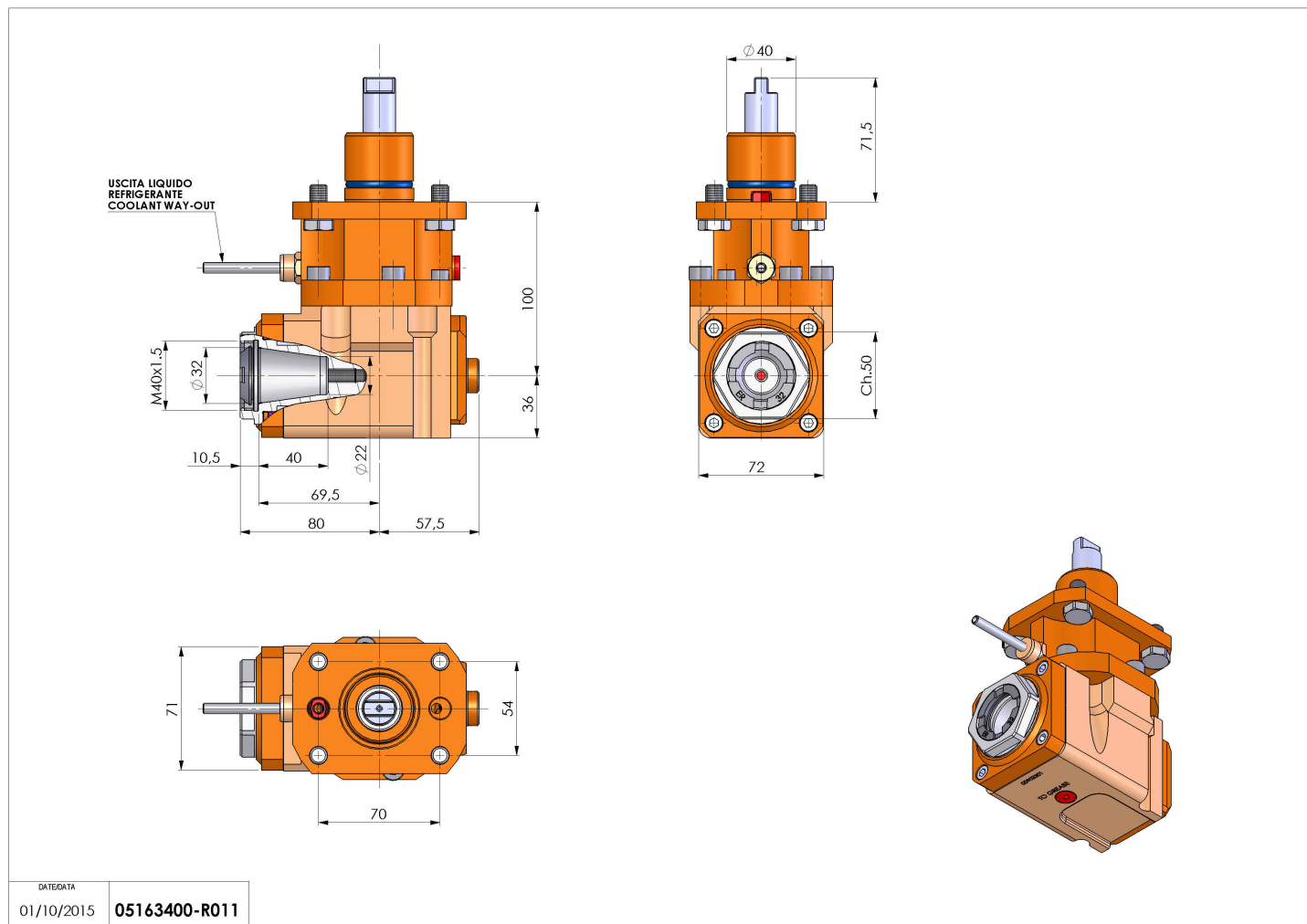

Salvo modifiche tecniche

DATE/DATE  
01/10/2015 05163400-R011