



05161000 - LT-S D35ER20FOF38.25RF1:2H95MU

Tipo	LT-S OFS Portautensili dritto offset
Attacco	CILINDRICO 35
Uscita utensile	Portapinza ER 20 F - ghiera interna
Raffreddamento	Refrigerazione interna
Offset [mm]	38,25
Senso di rotazione	r1  r2 
Velocità max [1/min]	in 6000 / out 12000
Coppia max [Nm]	in 10 / out 5
Rapporto	1:2
H [mm]	95
Pressione max [bar]	20
Accessori	N.D.
Note	N.D.
Note per il montaggio	N.D.



Verificare sempre gli ingombri del portautensile in torretta

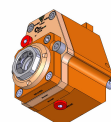
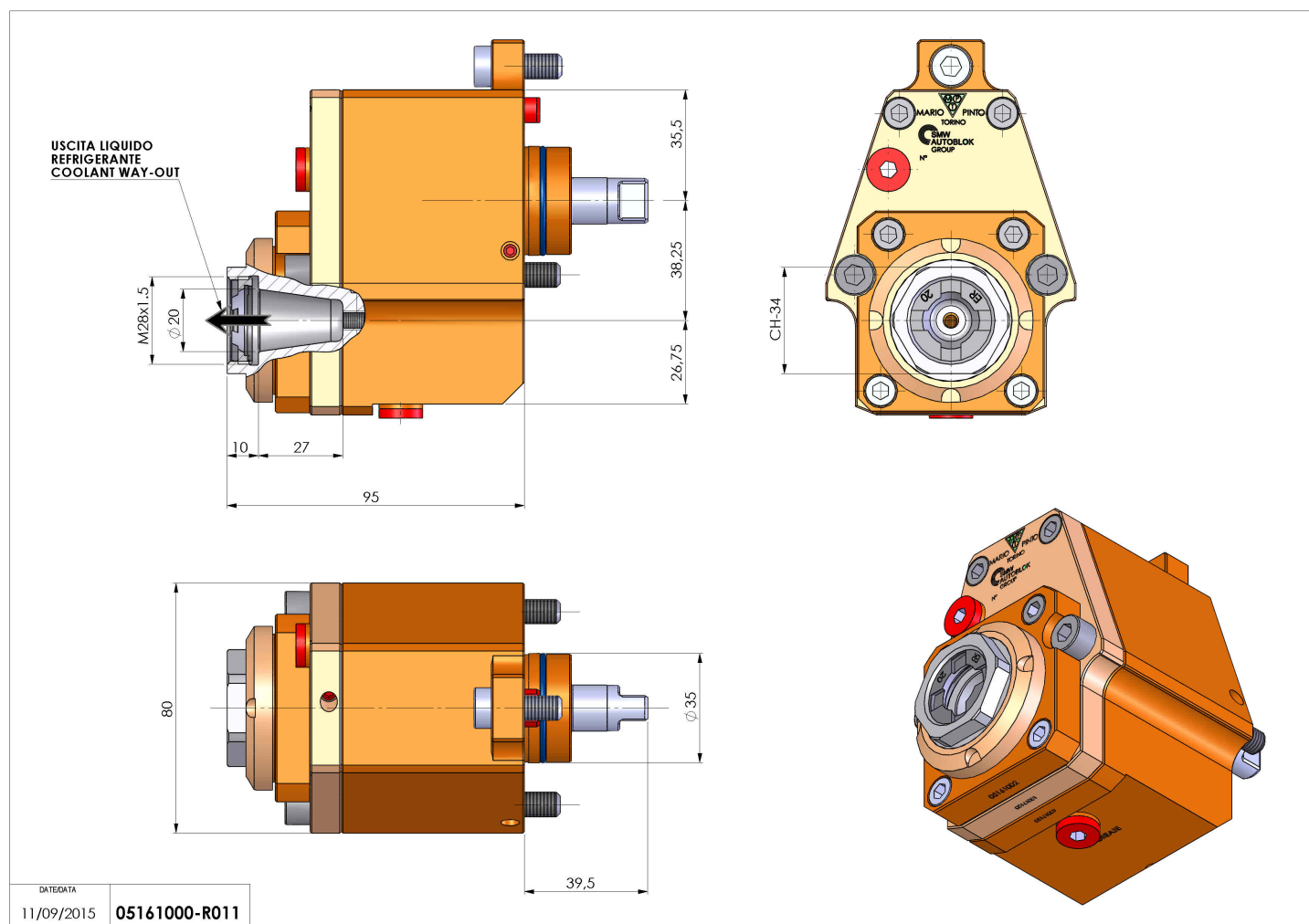

Salvo modifiche tecniche