



05126600 - LT-A BMT45 ER25F H65 DW

Tipo	LT-A Portautensili angolare a 90°
Attacco	BMT 45
Uscita utensile	Portapinza ER 25 F - ghiera interna
Raffreddamento	Refrigerazione esterna
Senso di rotazione	r1  r2 
Velocità max [1/min]	6000
Coppia max [Nm]	25
Rapporto	1:1
H [mm]	65
H1 [mm]	32,5
Accessori	N.D.
Note	N.D.
Note per il montaggio	Mandrino principale e secondario

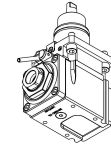

REPLACED BY 05338200

Verificare sempre gli ingombri del portautensile in torretta

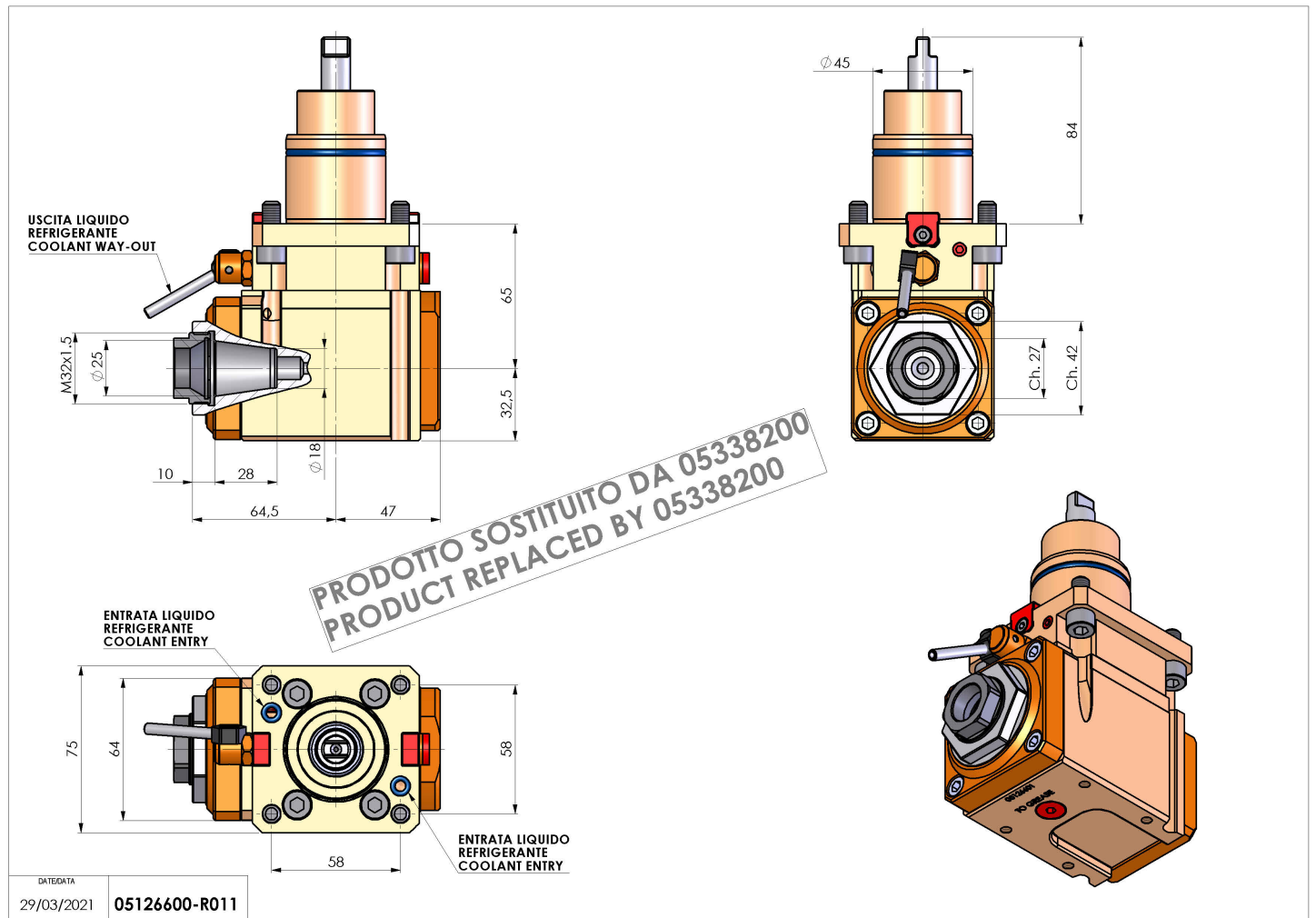

Salvo modifiche tecniche