

05080300 - LT-S D40 ER32F H70 AN

Tipo	LT-S Portautensili dritto
Attacco	CILINDRICO 40
Uscita utensile	Portapinza ER 32 F - ghiera interna
Raffreddamento	Refrigerazione esterna
Senso di rotazione	r1 r2
Velocità max [1/min]	6000
Coppia max [Nm]	63
Rapporto	1:1
H [mm]	70
Accessori	Chiave albero, chiave ghiera, ghiera per pinze ER
Note	Ad esaurimento. Sostituito da cod. 05085200
Note per il montaggio	N.D.

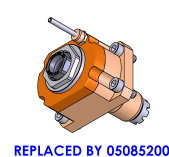

REPLACED BY 05085200

Verificare sempre gli ingombri del portautensile in torretta

USCITA LIQUIDO
REFRIGERANTE
COOLANT WAY-OUT

M40x1.5
Ø 32
14
35
70
Ø 23.5

92
Ch.32
Ch.50
52
80

PRODOTTO SOSTITUITO DA 05085200
PRODUCT REPLACED BY 05085200

100
Ø 40
68

REPLACED BY 05085200

DATE DATA	
29/05/2024	05080300-R012

Salvo modifiche tecniche