

05071900 - LT-S D40 P-FRE D16 H55 SPEC

Tipo	LT-S Portautensili dritto
Attacco	CILINDRICO 40
Uscita utensile	Portafrese DIN138 16
Raffreddamento	Refrigerazione esterna
Senso di rotazione	r1 r2
Velocità max [1/min]	6000
Coppia max [Nm]	25
Rapporto	1:1
H [mm]	55
Accessori	N.D.
Note	N.D.
Note per il montaggio	N.D.

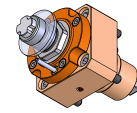

Verificare sempre gli ingombri del portautensile in torretta

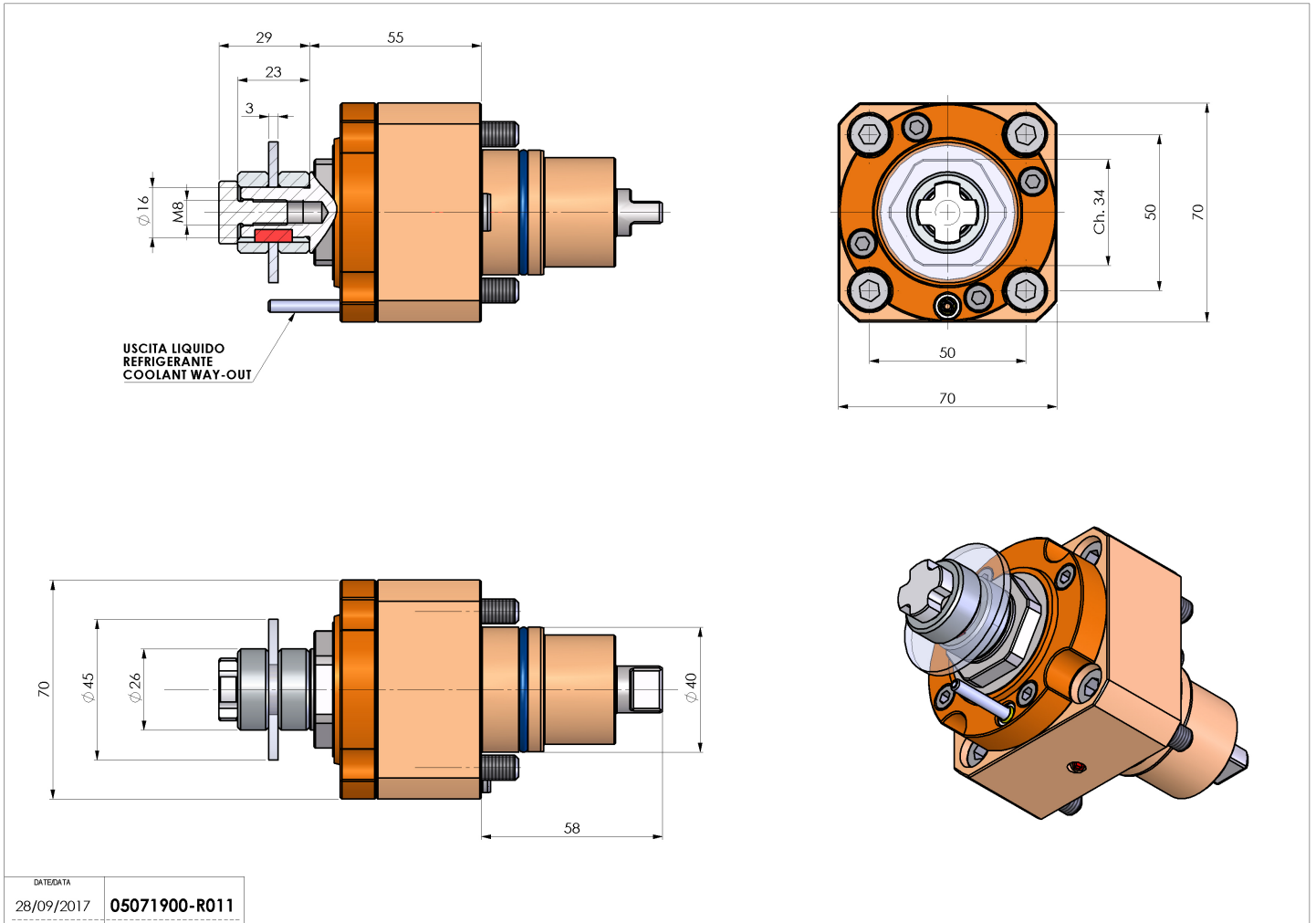

DATE/DATE	05071900-R011
28/09/2017	

Salvo modifiche tecniche