



05070400 - LT-S D40 ER20 H75 BI

Tipo	LT-S Portautensili dritto
Attacco	CILINDRICO 40
Uscita utensile	Portapinza ER 20
Raffreddamento	Refrigerazione esterna
Senso di rotazione	r1  r2 
Velocità max [1/min]	6000
Coppia max [Nm]	25
Rapporto	1:1
H [mm]	75
Accessori	Chiave albero, chiave ghiera, ghiera per pinze ER
Note	N.D.
Note per il montaggio	N.D.



Verificare sempre gli ingombri del portautensile in torretta

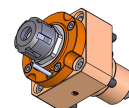
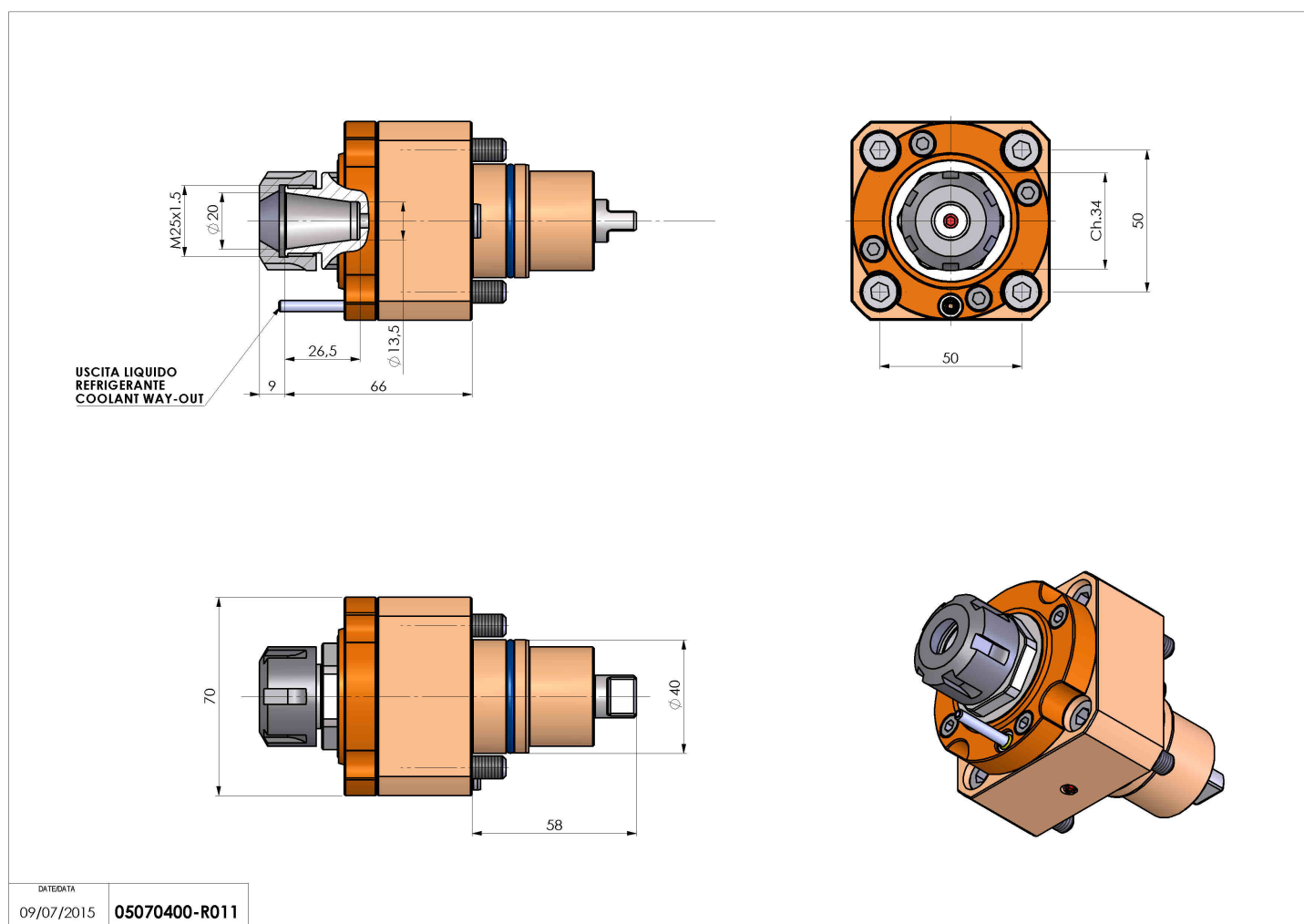

Salvo modifiche tecniche