



05016200 - LT-A D55 ER32F HRF H65

Tipo	LT-A Portautensili angolare a 90°
Attacco	CILINDRICO 55
Uscita utensile	Portapinza ER 32 F - ghiera interna
Raffreddamento	Refrigerazione interna HRF
Senso di rotazione	r1  r2 
Velocità max [1/min]	6000
Coppia max [Nm]	40
Rapporto	1:1
H [mm]	65
H1 [mm]	36
Pressione max [bar]	80
Accessori	N.D.
Note	N.D.
Note per il montaggio	N.D.



Verificare sempre gli ingombri del portautensile in torretta

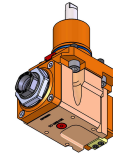
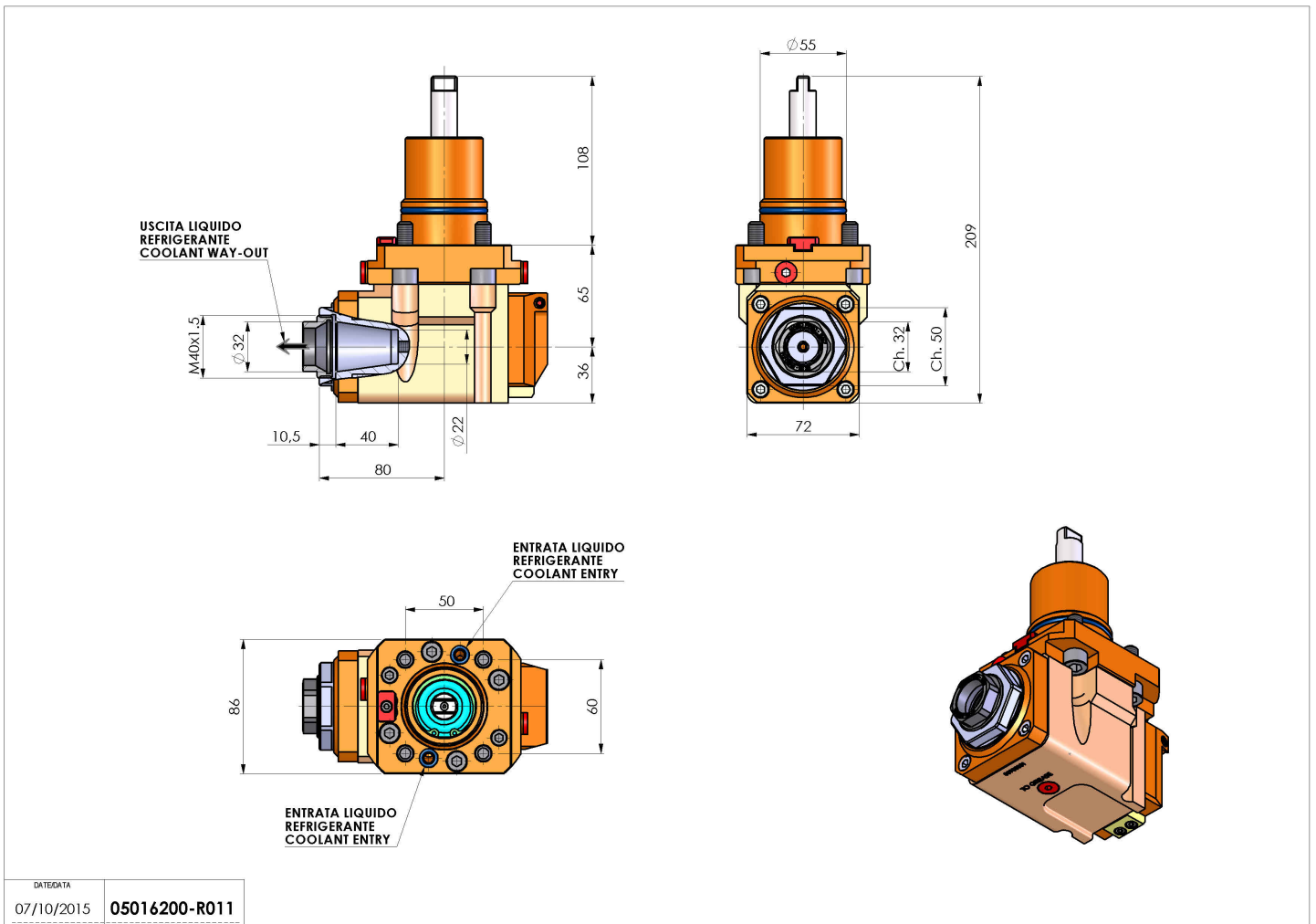

DATE/ATA	07/10/2015	05016200-R011
----------	------------	---------------

Salvo modifiche tecniche