

05519300 - LT-A BMT85 BD ISO-BT40 RF H85 2:1

Type	LT-A Tool holder angle 90°
Mounting	BMT 85 BIG DRIVE
Tool output	Quick Change ISO-BT40
Coolant	Internal coolant
Direction of rotation	r1 r2
Max speed [rpm]	in 4000 / out 2000
Max torque [Nm]	in 60 / out 120
Ratio	2:1
H [mm]	85
H1 [mm]	52
Accessories	N.A.
Notes	N.A.
Mounting tips	N.A.

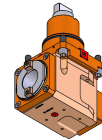

Always check live tool dimensions on the turret

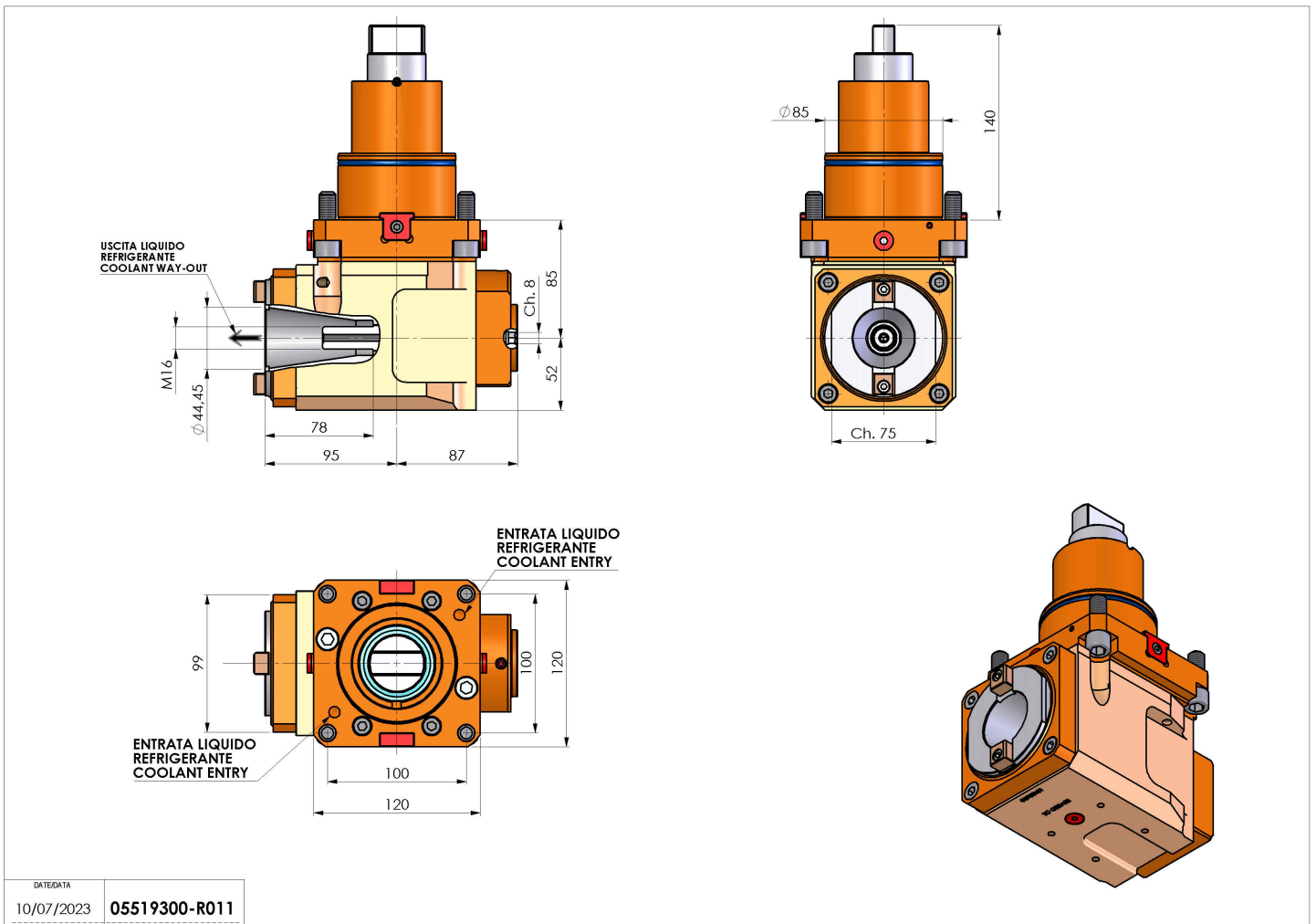

DATE/DATE	10/07/2023
PART NUMBER	05519300-R011

Subject to technical changes