

# 05518100 - LT-S BMT85 BD DIN138-32 H77

Type	LT-S Tool holder straight
Mounting	BMT 85 BIG DRIVE
Tool output	Shell-Mill DIN138 32
Coolant	External coolant
Direction of rotation	r1 ↻ r2 ↻
Max speed [rpm]	4000
Max torque [Nm]	100
Ratio	1:1
H [mm]	77
Accessories	N.A.
Notes	N.A.
Mounting tips	N.A.

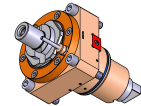

Always check live tool dimensions on the turret

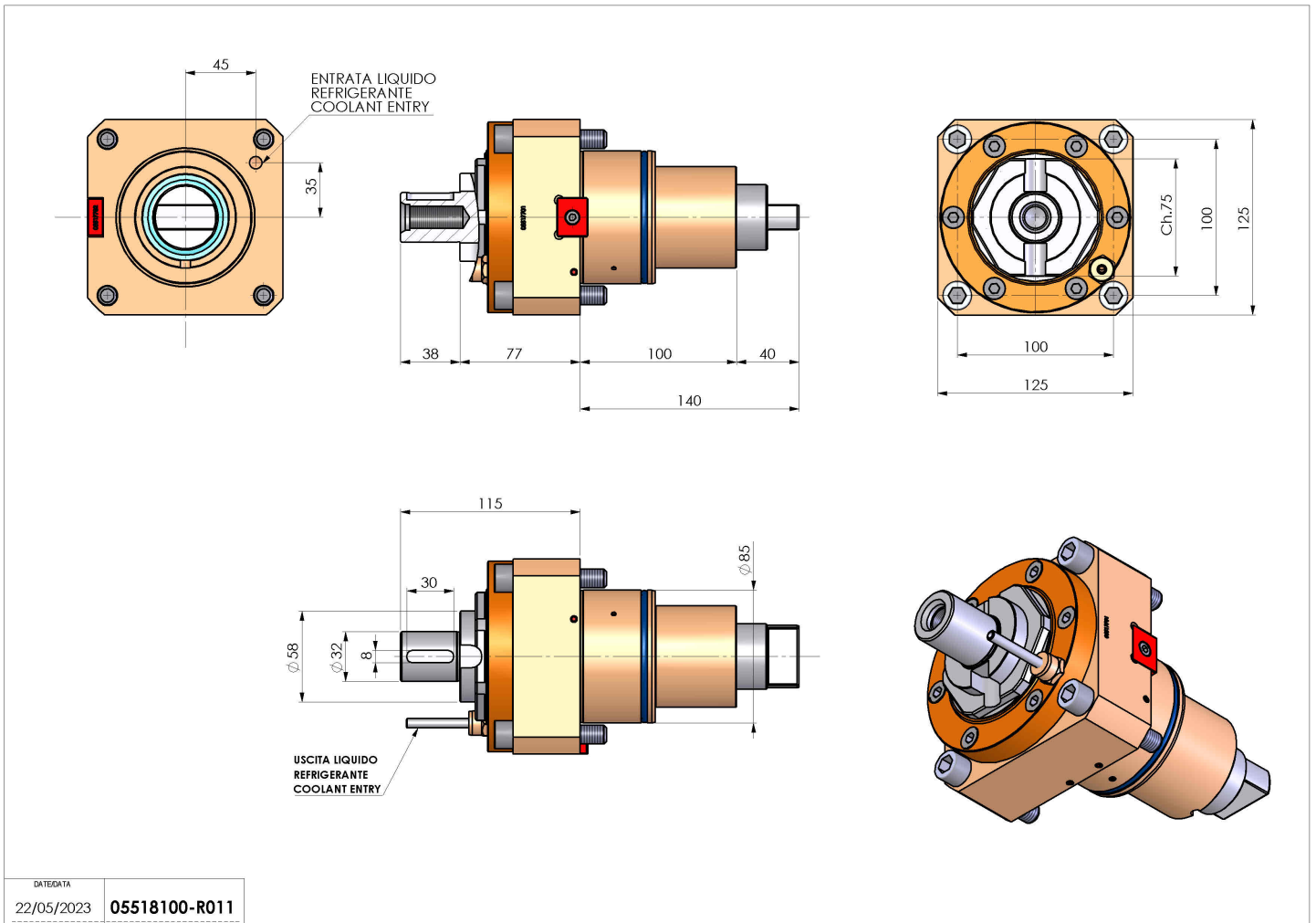

DATE/DATE	05518100-R011
22/05/2023	

Subject to technical changes