

## 05515500 - LT-A BMT75 BD ER32F RF OF LR 1:2 H90

<b>Type</b>	LT-A OFS Tool holder offset angle 90°
<b>Mounting</b>	BMT 75 BIG DRIVE
<b>Tool output</b>	Collet nut ER 32 F - internal nut
<b>Coolant</b>	Internal coolant
<b>Direction of rotation</b>	r1 ↻ r2 ↻
<b>Max speed [rpm]</b>	in 4000 / out 8000
<b>Max torque [Nm]</b>	in 50 / out 25
<b>Ratio</b>	1:2
<b>H [mm]</b>	90
<b>H1 [mm]</b>	38
<b>Max pressure [bar]</b>	20
<b>Accessories</b>	N.A.
<b>Notes</b>	N.A.
<b>Mounting tips</b>	Main and secondary spindle

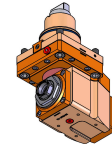

Always check live tool dimensions on the turret

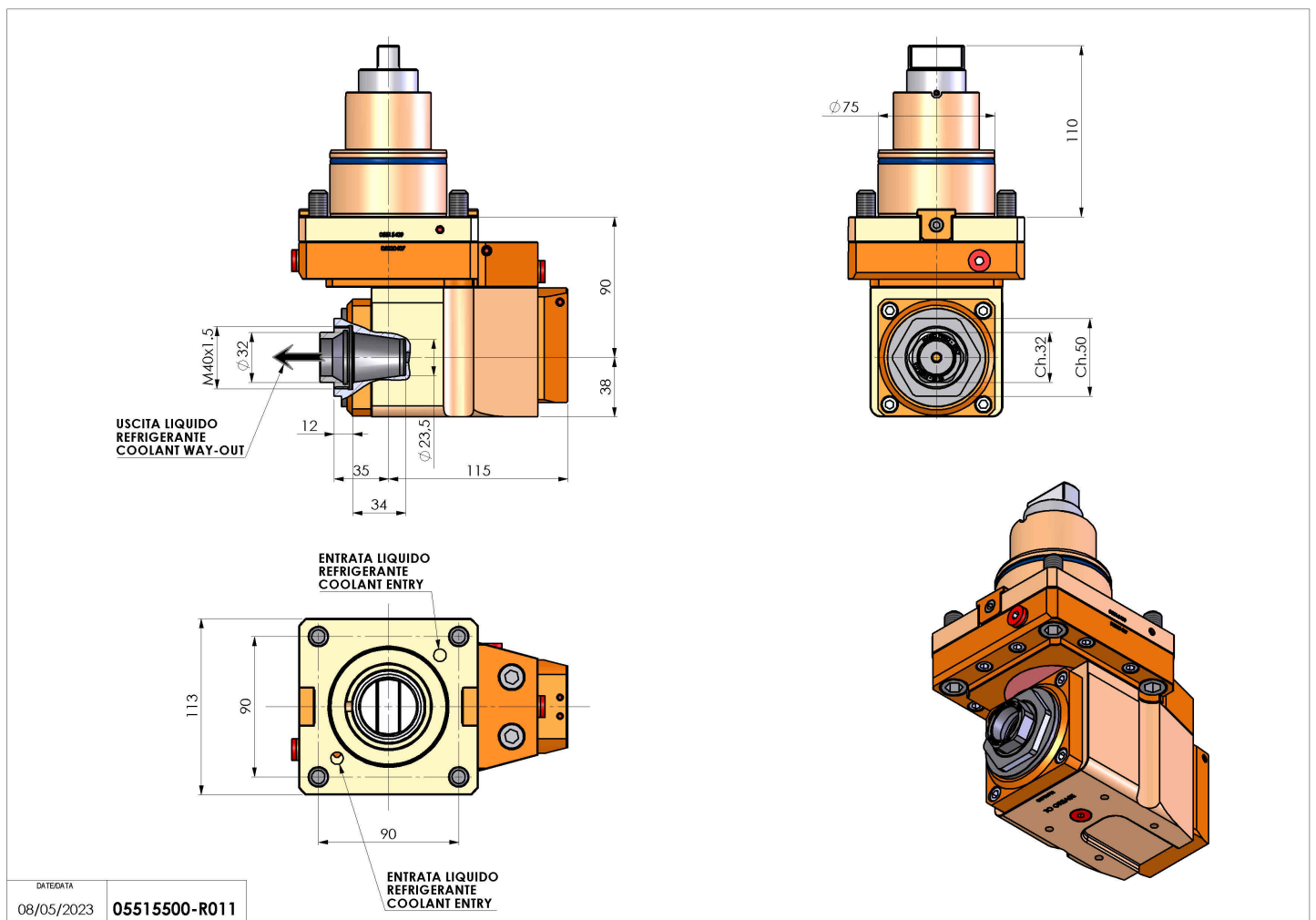

DATE/DATA  
08/05/2023 05515500-R011

Subject to technical changes