

05482700 - LT-A VDI40 ER32F HRF H100 FA

| | |
|-----------------------|-----------------------------------|
| Type | LT-A Tool holder angle 90° |
| Mounting | VDI 40 |
| Tool output | Collet nut ER 32 F - internal nut |
| Coolant | HRF Internal coolant |
| Direction of rotation | r1 ↻ r2 ↻ |
| Max speed [rpm] | 8000 |
| Max torque [Nm] | 80 |
| Ratio | 1:1 |
| H [mm] | 100 |
| H1 [mm] | 38 |
| Max pressure [bar] | 80 |
| Accessories | N.A. |
| Notes | N.A. |
| Mounting tips | N.A. |

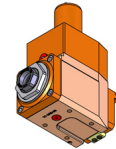

ATTENTION: CHECK THE ORIENTATION OF THE VDI TEETH

Always check live tool dimensions on the turret

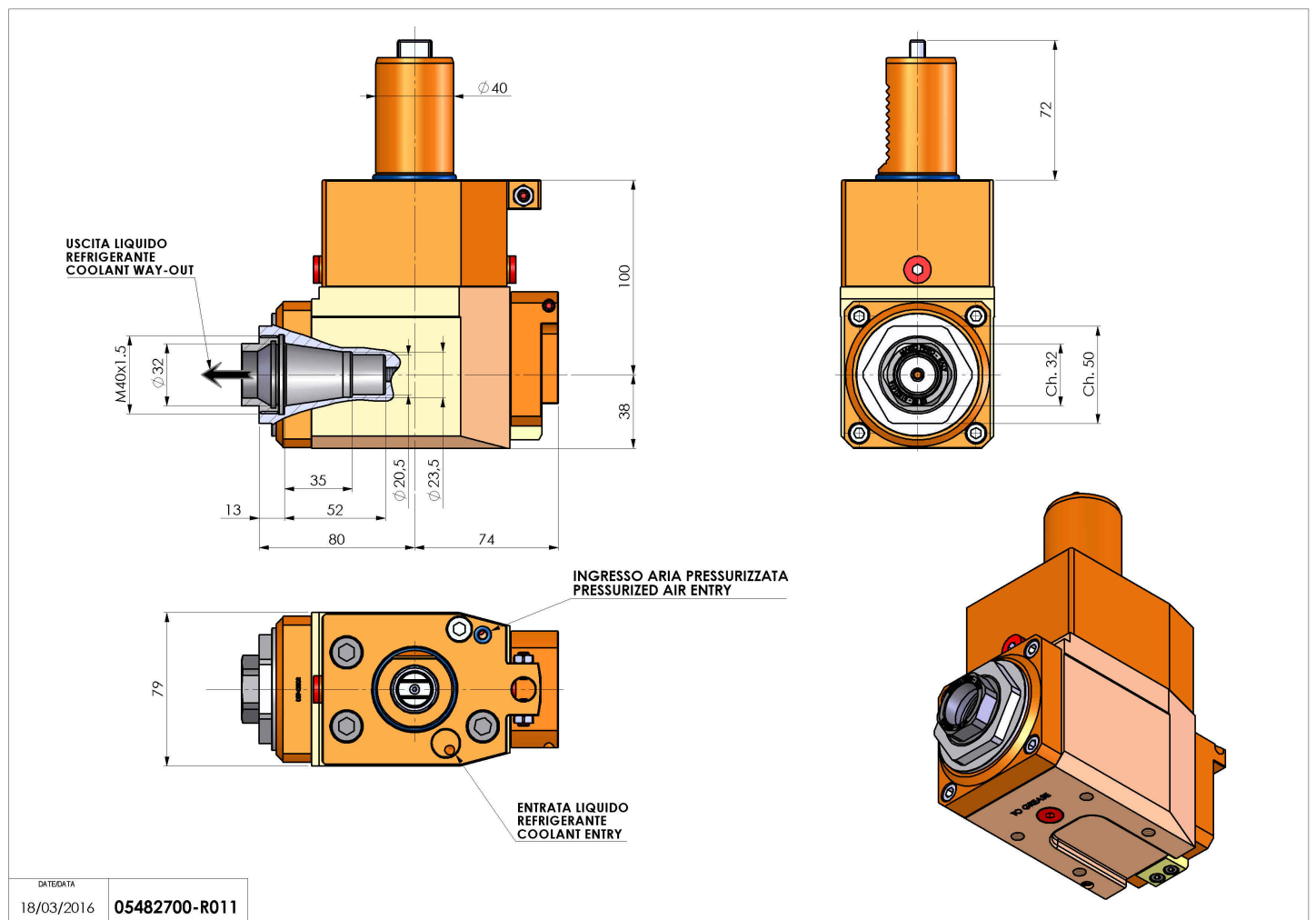

DATE/GATE
18/03/2016 05482700-R011

Subject to technical changes