

05480800 - LT-S D70 ER32 H87 FA

Type	LT-S Tool holder straight
Mounting	CYLINDRICAL SHANK 70
Tool output	Collet nut ER 32
Coolant	External coolant
Direction of rotation	r1  r2 
Max speed [rpm]	8000
Max torque [Nm]	80
Ratio	1:1
H [mm]	87
Accessories	
Notes	N.A.
Mounting tips	N.A.

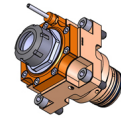

Always check live tool dimensions on the turret

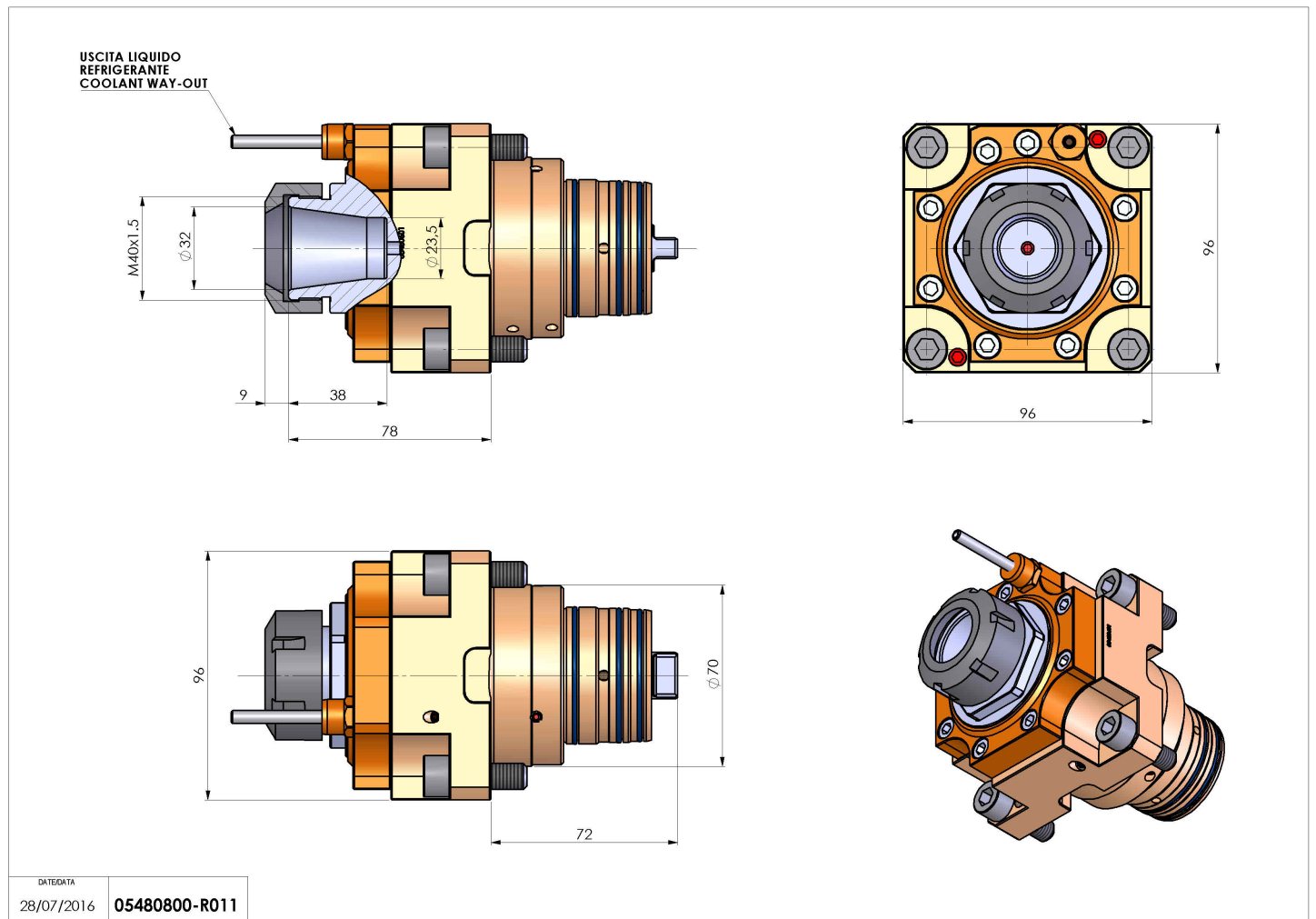

Subject to technical changes