

# 05456100 - LT-A2H VDI40 ER16 H100

Type	LT-A2 H Tool holder angle 90° double horizontal
Mounting	VDI 40
Tool output	Collet nut ER 16
Coolant	External coolant
Direction of rotation	r1 ↻ r2 ↻
Max speed [rpm]	6000
Max torque [Nm]	30
Ratio	1:1
H [mm]	100
H1 [mm]	35
Accessories	N.A.
Notes	N.A.
Mounting tips	N.A.

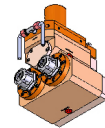

**ATTENTION: CHECK THE ORIENTATION OF THE VDI TEETH**

Always check live tool dimensions on the turret

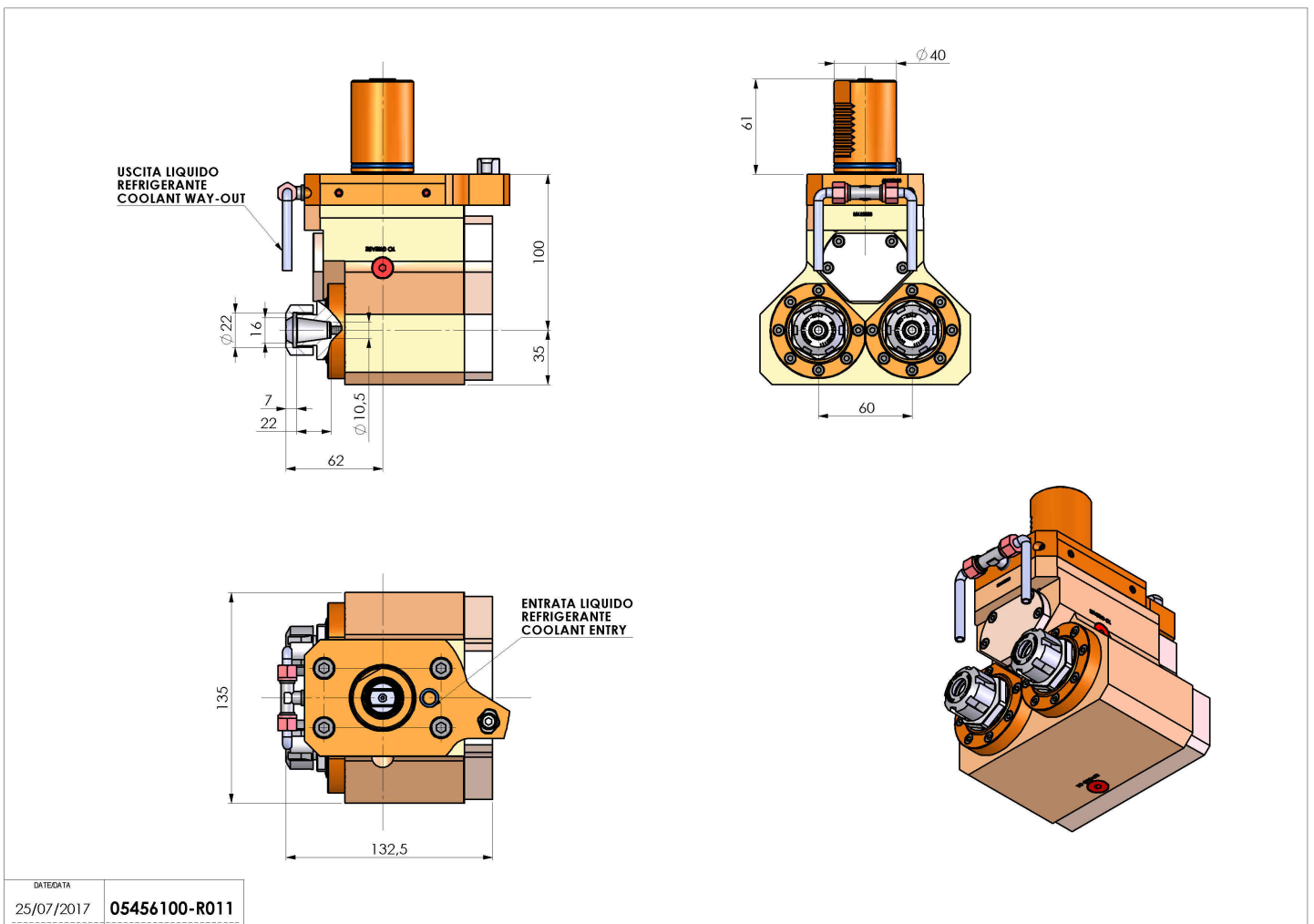

DATE/DATE	05456100-R011
25/07/2017	

Subject to technical changes