

05450500 - LT-A D68 ER25F-25F OFS 1:2 H90

Type	LT-A OFS DBL Tool holder double offset angle 90°
Mounting	CYLINDRICAL SHANK 68
Tool output	Collet nut ER 25 F - internal nut
Coolant	External coolant
Direction of rotation	r1 ↻ r2 ↻ r3 ↻
Max speed [rpm]	6000
Max torque [Nm]	40
Ratio	1:2
H [mm]	90
H1 [mm]	34
Accessories	N.A.
Notes	N.A.
Mounting tips	N.A.

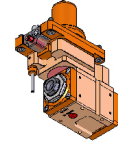

Always check live tool dimensions on the turret

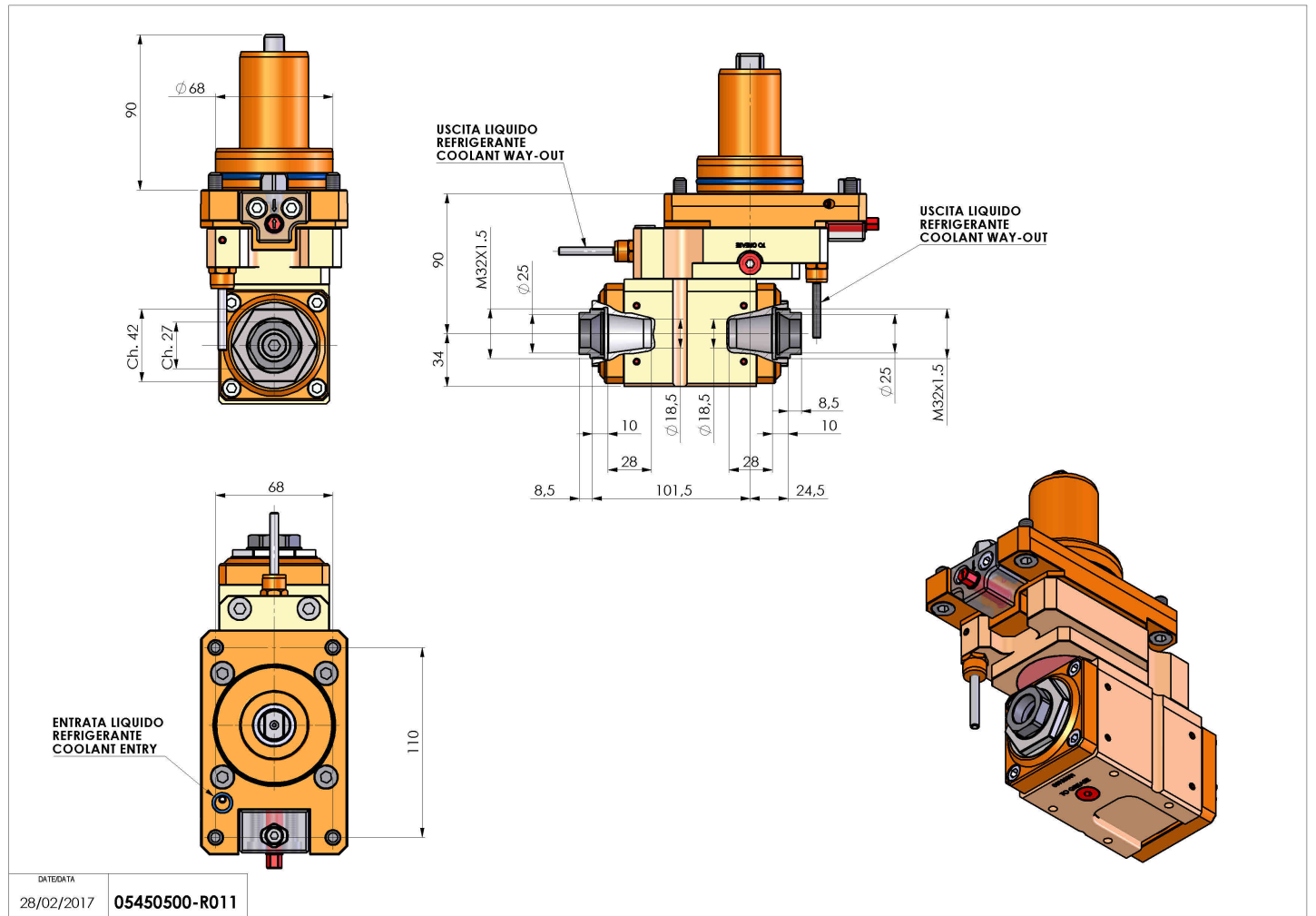

DATE/DATA
28/02/2017 05450500-R011

Subject to technical changes