

05450200 - LT-A D68 ER25F OFS1:1.75S RFHS H84.5

Type	LT-A OFS Tool holder offset angle 90°
Mounting	CYLINDRICAL SHANK 68
Tool output	Collet nut ER 25 F - internal nut
Coolant	Internal coolant
Direction of rotation	r1 ↻ r2 ↻
Max speed [rpm]	10000
Max torque [Nm]	25
Ratio	1:1,75
H [mm]	84,5
H1 [mm]	32,5
Max pressure [bar]	20
Accessories	N.A.
Notes	N.A.
Mounting tips	Secondary spindle only

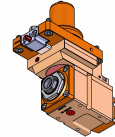

Always check live tool dimensions on the turret

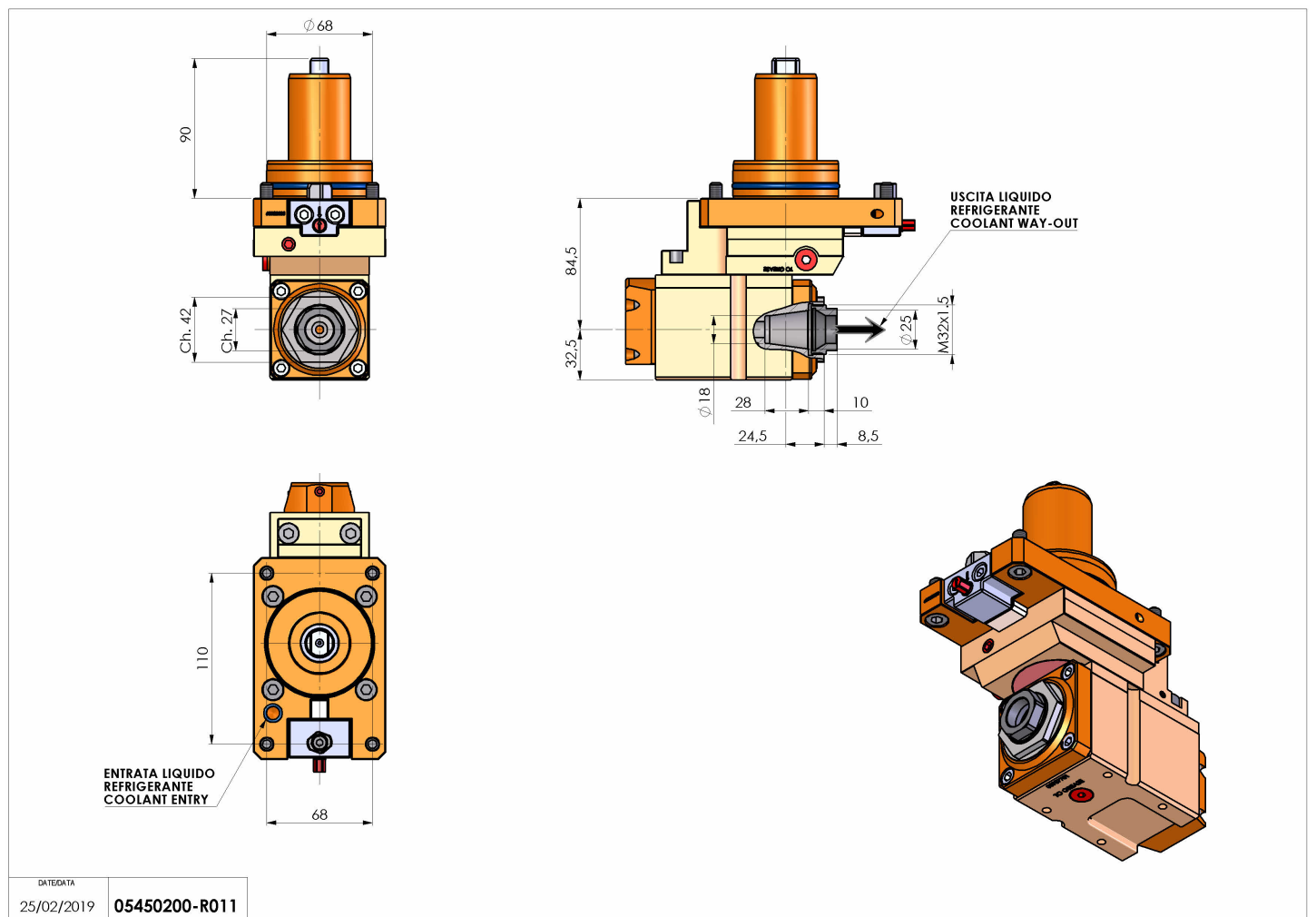

DATE/DATE
25/02/2019 05450200-R011

Subject to technical changes