

05414000 - LT-A D44 ER25F-25F L-R H75

| | |
|------------------------------|--|
| Type | LT-A DBL Tool holder double angle 90° |
| Mounting | CYLINDRICAL SHANK 44 |
| Tool output | Collet nut ER 25 F - internal nut |
| Coolant | External coolant |
| Direction of rotation | r1 ↻ r2 ↻ r3 ↻ |
| Max speed [rpm] | 6000 |
| Max torque [Nm] | 30 |
| Ratio | 1:1 |
| H [mm] | 75 |
| H1 [mm] | 34 |
| Accessories | N.A. |
| Notes | N.A. |
| Mounting tips | Main and secondary spindle |

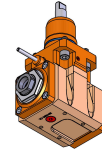

Always check live tool dimensions on the turret

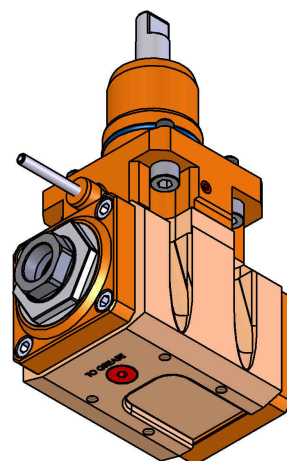
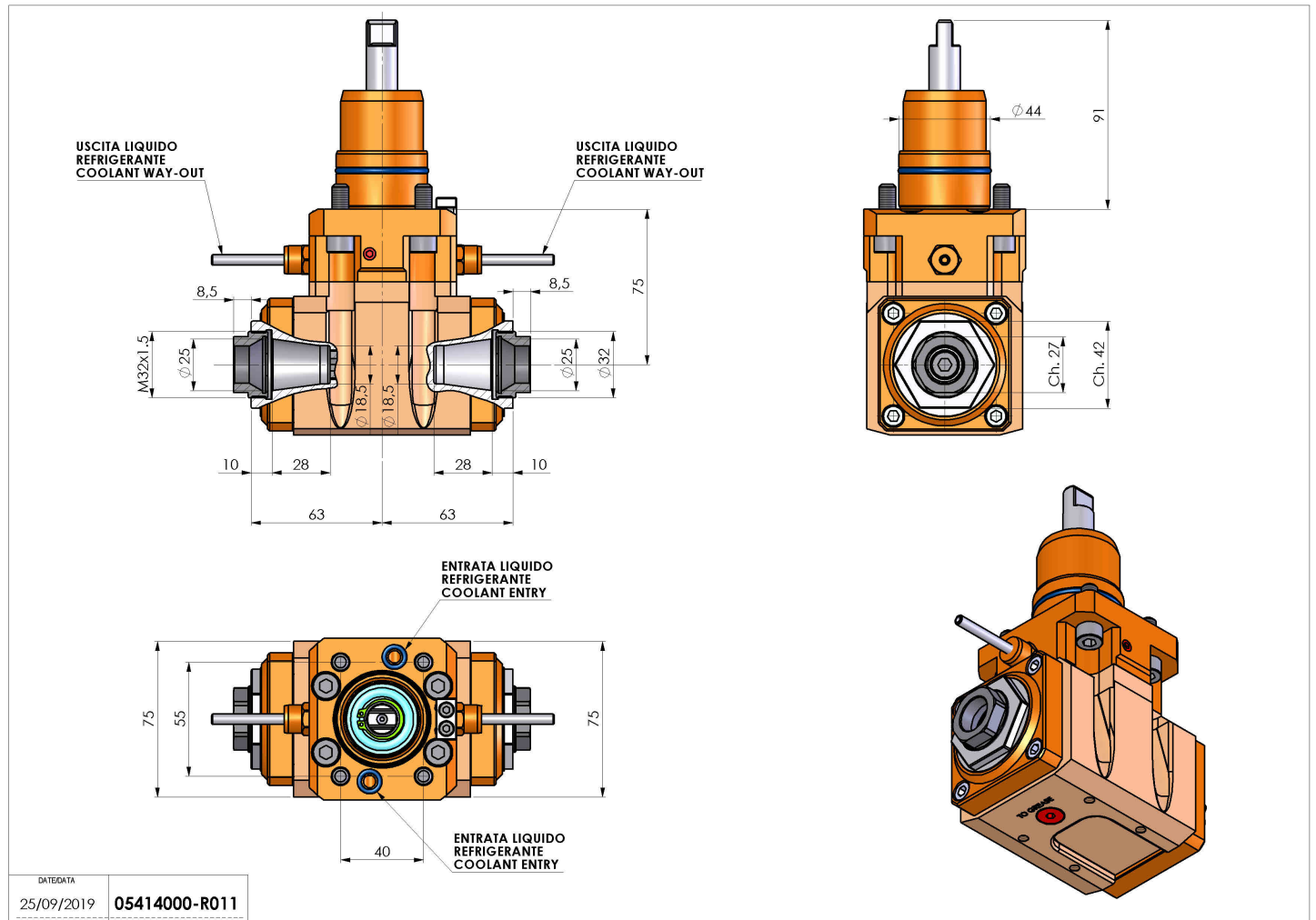

Subject to technical changes

| | |
|------------|---------------|
| DATE/DATA | 05414000-R011 |
| 25/09/2019 | |