

05390600 - LT-A D45 BD ER25 HRF 1:2 H65

Type	LT-A Tool holder angle 90°
Mounting	CYLINDRICAL SHANK 45
Tool output	Collet nut ER 25
Coolant	HRF Internal coolant
Direction of rotation	r1 ↻ r2 ↻
Max speed [rpm]	in 5000 / out 10000
Max torque [Nm]	in 10 / out 5
Ratio	1:2
H [mm]	65
H1 [mm]	32.5
Max pressure [bar]	80
Accessories	N.A.
Notes	N.A.
Mounting tips	N.A.

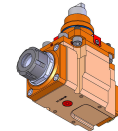

Always check live tool dimensions on the turret

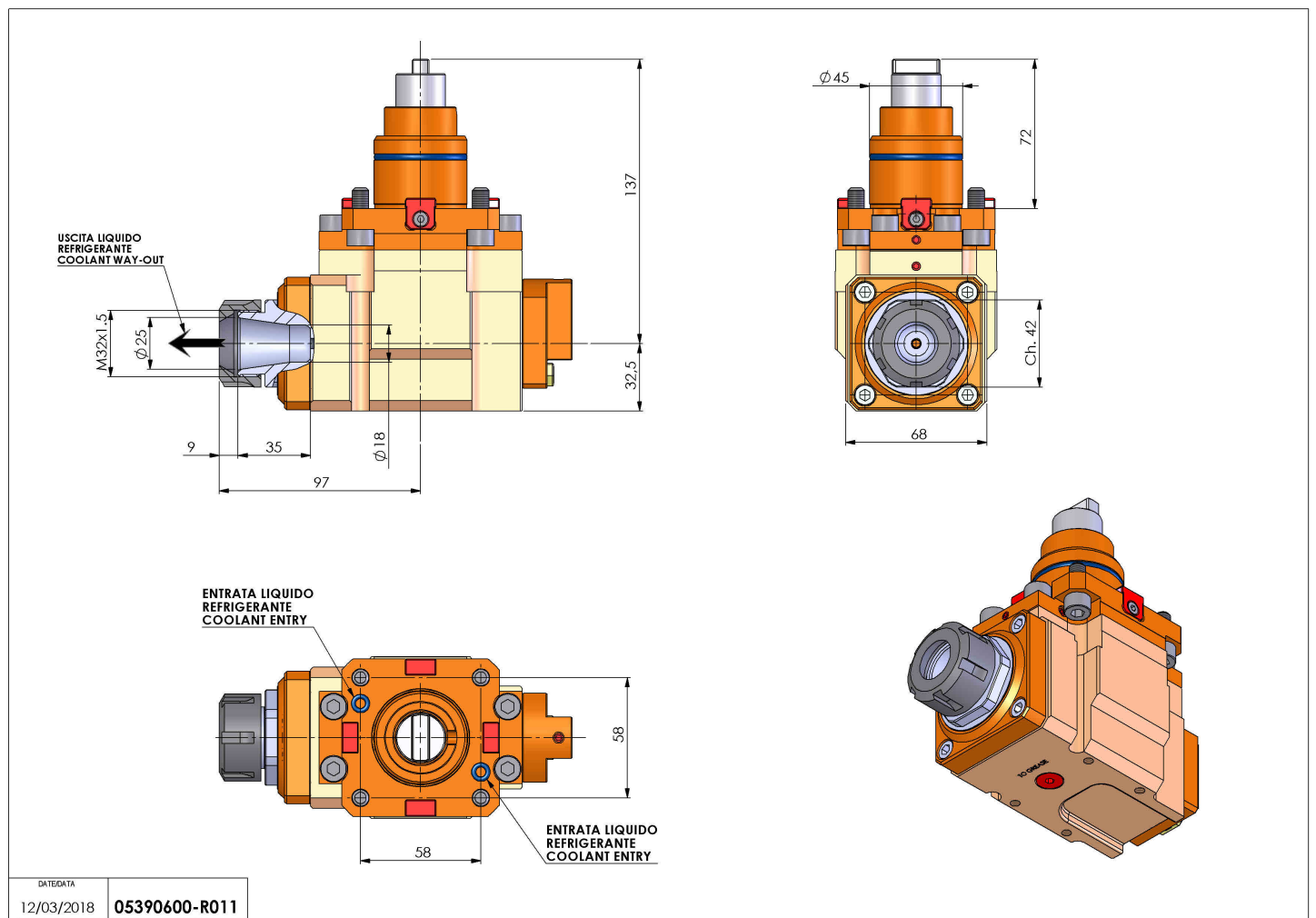

Subject to technical changes