

05385800 - LT-A2H D65 I:60 DBL ER25 H94

Type	LT-A2 H DBL Tool holder angle 90° double horizontal
Mounting	CYLINDRICAL SHANK 65
Tool output	Collet nut ER 25
Coolant	External coolant
Direction of rotation	r1 ↻ r2 ↻ r3 ↻
Max speed [rpm]	6000
Max torque [Nm]	40
Ratio	1:1
H [mm]	94
H1 [mm]	32.5
Accessories	N.A.
Notes	N.A.
Mounting tips	N.A.

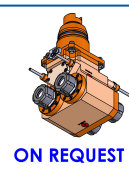

Always check live tool dimensions on the turret

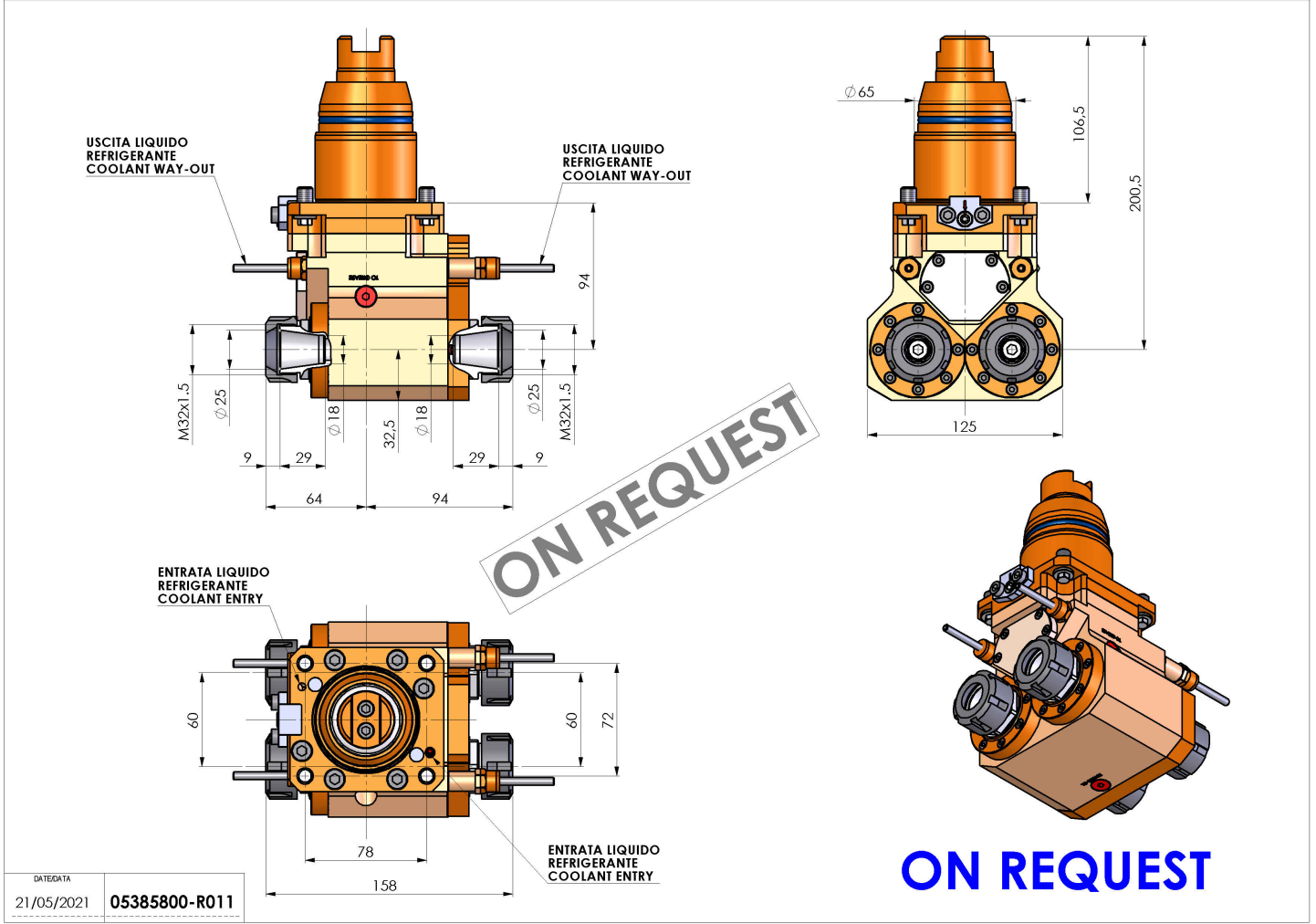

Subject to technical changes