

05371700 - LT-S D55 C40 HRF H70

Type	LT-S Tool holder straight
Mounting	CYLINDRICAL SHANK 55
Tool output	Polygonal shank C40 ISO 26623-1
Coolant	HRF Internal coolant
Direction of rotation	r1 r2
Max speed [rpm]	6000
Max torque [Nm]	63
Ratio	1:1
H [mm]	70
Max pressure [bar]	70
Accessories	N.A.
Notes	N.A.
Mounting tips	Main and secondary spindle

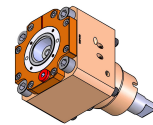

Always check live tool dimensions on the turret

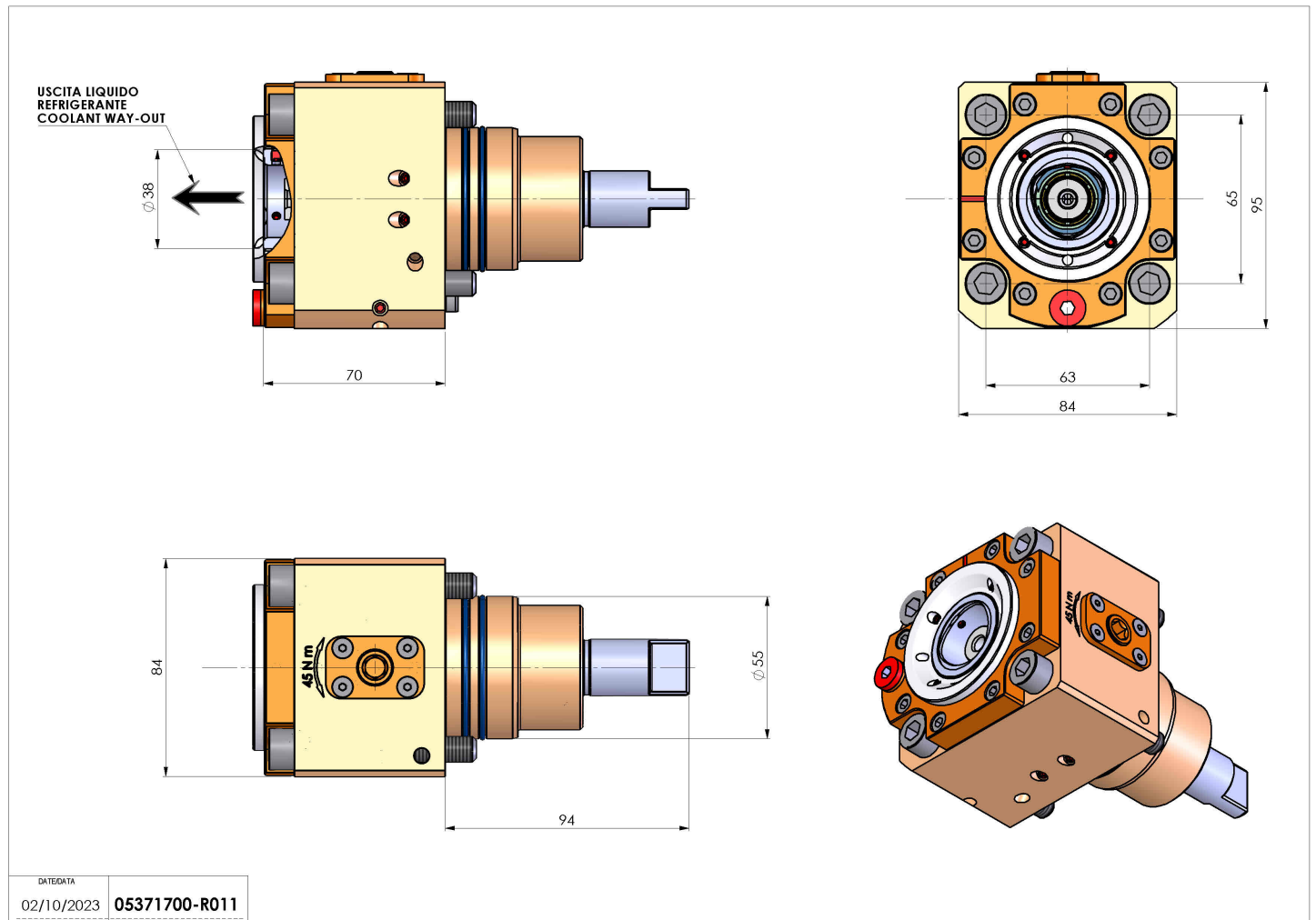

DATE/DATE	
02/10/2023	05371700-R011

Subject to technical changes