

# 05371400 - LT-S D55 HSK40 HRF H86.5

<b>Type</b>	LT-S Tool holder straight
<b>Mounting</b>	CYLINDRICAL SHANK 55
<b>Tool output</b>	Quick Change HSK40
<b>Coolant</b>	HRF Internal coolant
<b>Direction of rotation</b>	r1  r2
<b>Max speed [rpm]</b>	6000
<b>Max torque [Nm]</b>	63
<b>Ratio</b>	1:1
<b>H [mm]</b>	86.5
<b>Max pressure [bar]</b>	70
<b>Accessories</b>	N.A.
<b>Notes</b>	N.A.
<b>Mounting tips</b>	Main and secondary spindle

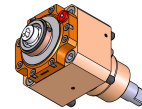

Always check live tool dimensions on the turret

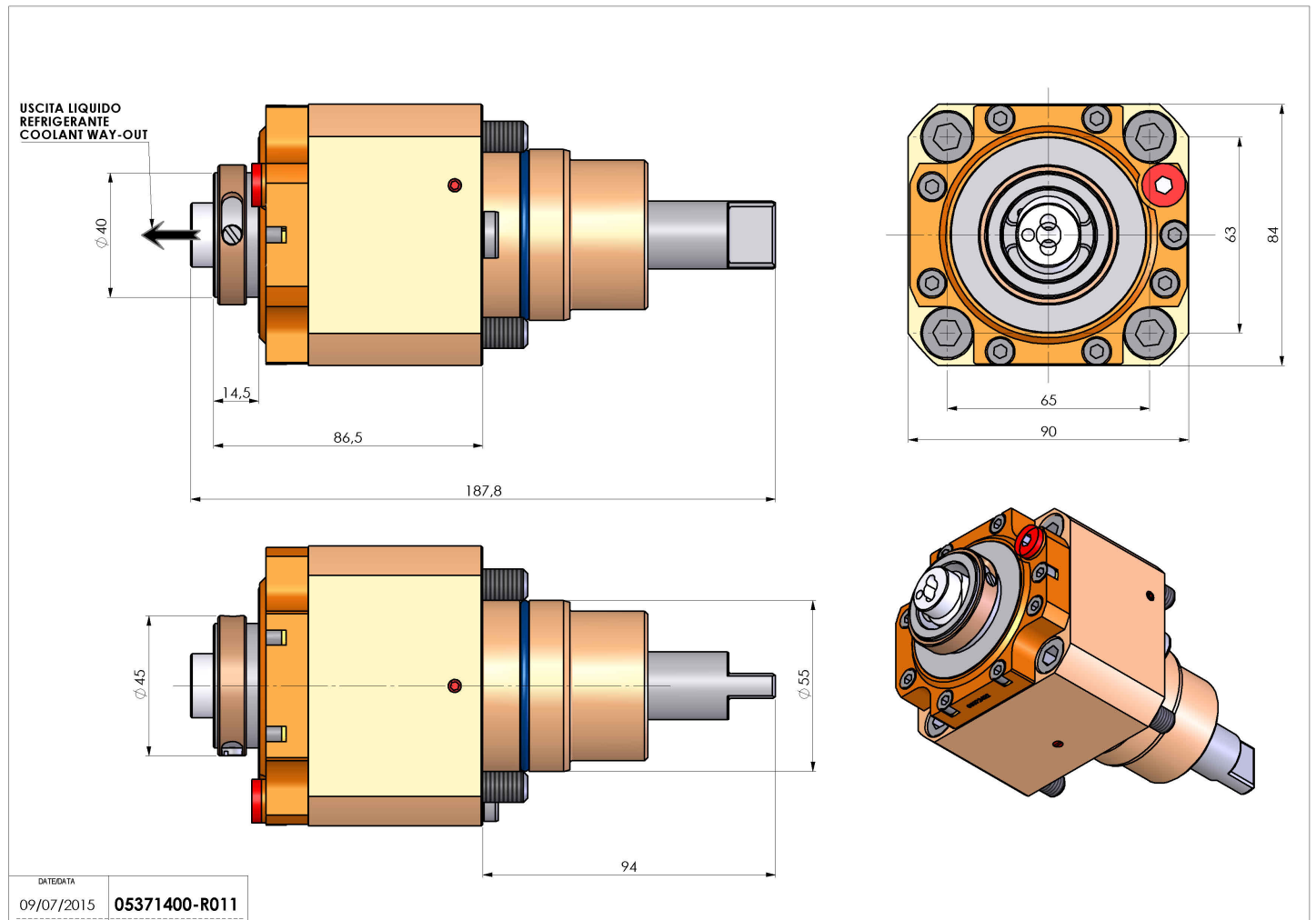

Subject to technical changes