

# 05359500 - LT-S D68 ER20F OFS78 1:3HRF H

<b>Type</b>	LT-S OFS Tool holder straight offset
<b>Mounting</b>	CYLINDRICAL SHANK 68
<b>Tool output</b>	Collet nut ER 20 F - internal nut
<b>Coolant</b>	HRF Internal coolant
<b>Offset [mm]</b>	78
<b>Direction of rotation</b>	r1  r2
<b>Max speed [rpm]</b>	in 5000 / out 15000
<b>Max torque [Nm]</b>	in 50 / out 14
<b>Ratio</b>	1:3
<b>H [mm]</b>	90
<b>Max pressure [bar]</b>	80
<b>Accessories</b>	N.A.
<b>Notes</b>	N.A.
<b>Mounting tips</b>	Main spindle only

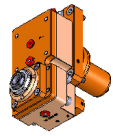

Always check live tool dimensions on the turret

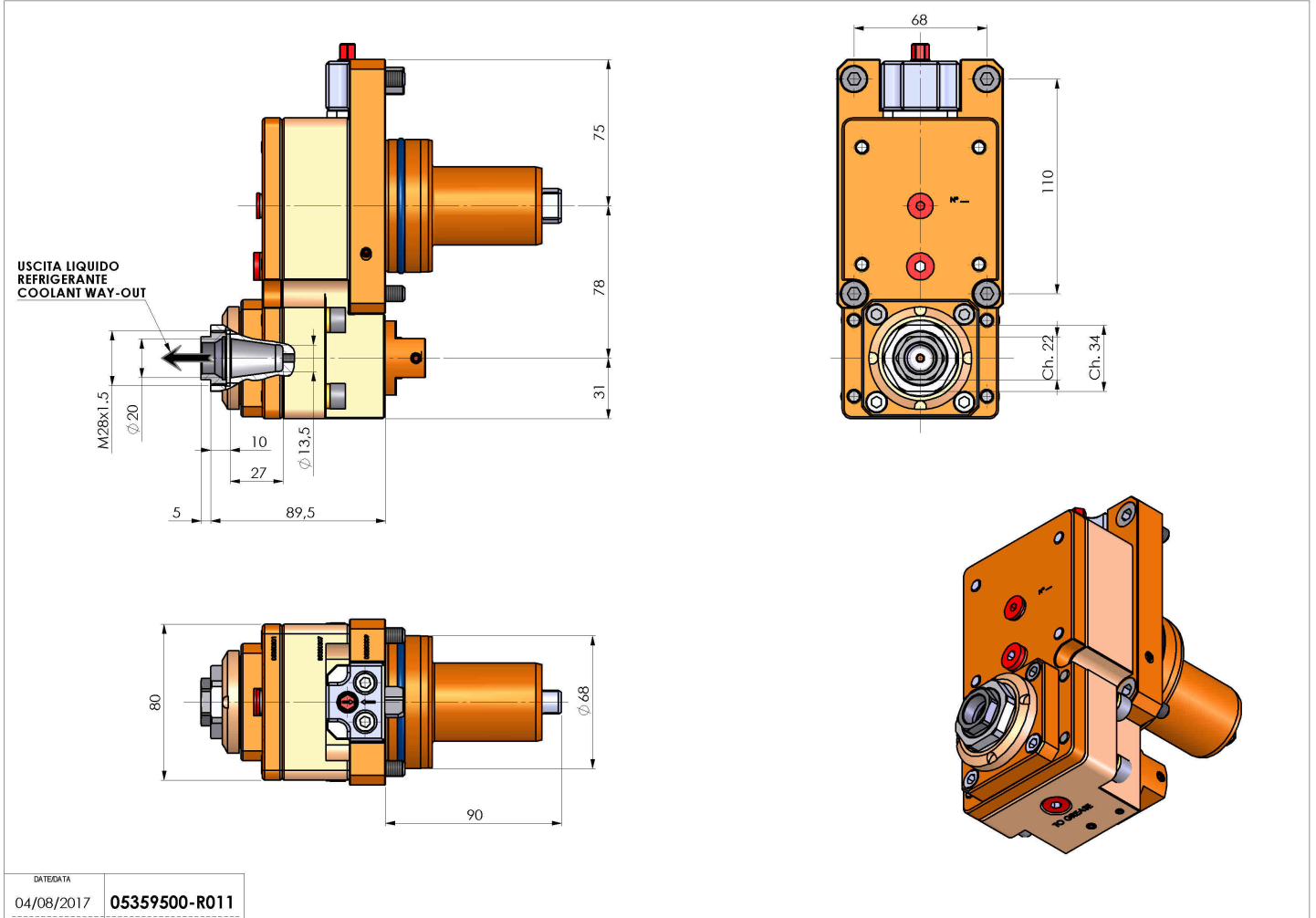

DATE/DATE	
04/08/2017	<b>05359500-R011</b>

Subject to technical changes