

# 05359400 - LT-S D68 ER25F OFS78 HRF H90

<b>Type</b>	LT-S OFS Tool holder straight offset
<b>Mounting</b>	CYLINDRICAL SHANK 68
<b>Tool output</b>	Collet nut ER 25 F - internal nut
<b>Coolant</b>	HRF Internal coolant
<b>Offset [mm]</b>	78
<b>Direction of rotation</b>	r1 ↻ r2 ↻
<b>Max speed [rpm]</b>	6000
<b>Max torque [Nm]</b>	50
<b>Ratio</b>	1:1
<b>H [mm]</b>	90
<b>Max pressure [bar]</b>	80
<b>Accessories</b>	N.A.
<b>Notes</b>	N.A.
<b>Mounting tips</b>	Main spindle only

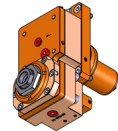

Always check live tool dimensions on the turret

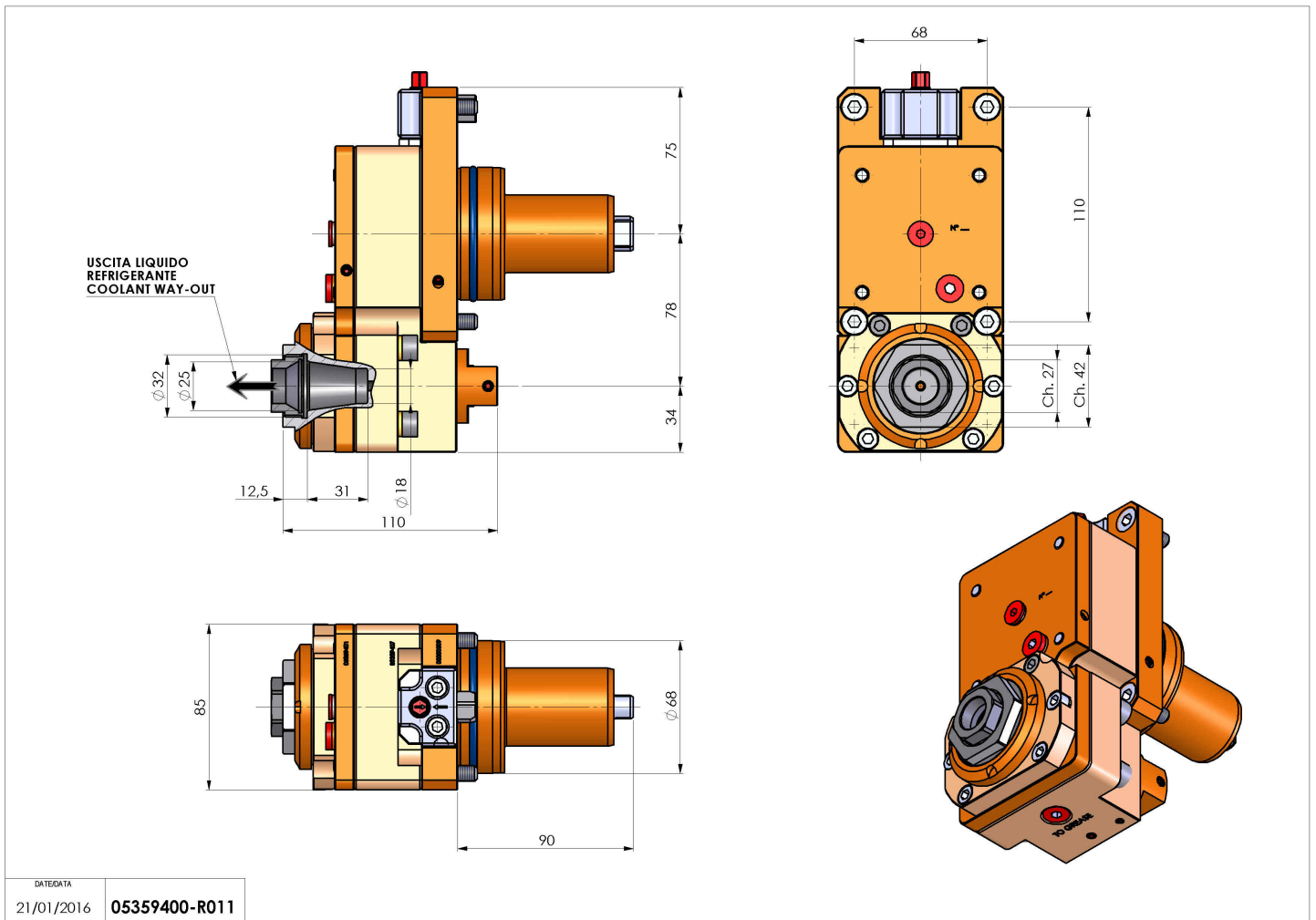

DATE/DATE	05359400-R011
21/01/2016	

Subject to technical changes