

# 05357500 - LT-S VDI40 ER32F OF512:1HSH104

Type	LT-S OFS Tool holder straight offset
Mounting	VDI 40
Tool output	Collet nut ER 32 F - internal nut
Coolant	External coolant
Offset [mm]	51
Direction of rotation	r1 ↻ r2 ↻
Max speed [rpm]	in 10000 / out 5000
Max torque [Nm]	in 60 / out 120
Ratio	2:1
H [mm]	104
Accessories	N.A.
Notes	N.A.
Mounting tips	N.A.

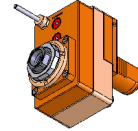

**ATTENTION: CHECK THE ORIENTATION OF THE VDI TEETH**

Always check live tool dimensions on the turret

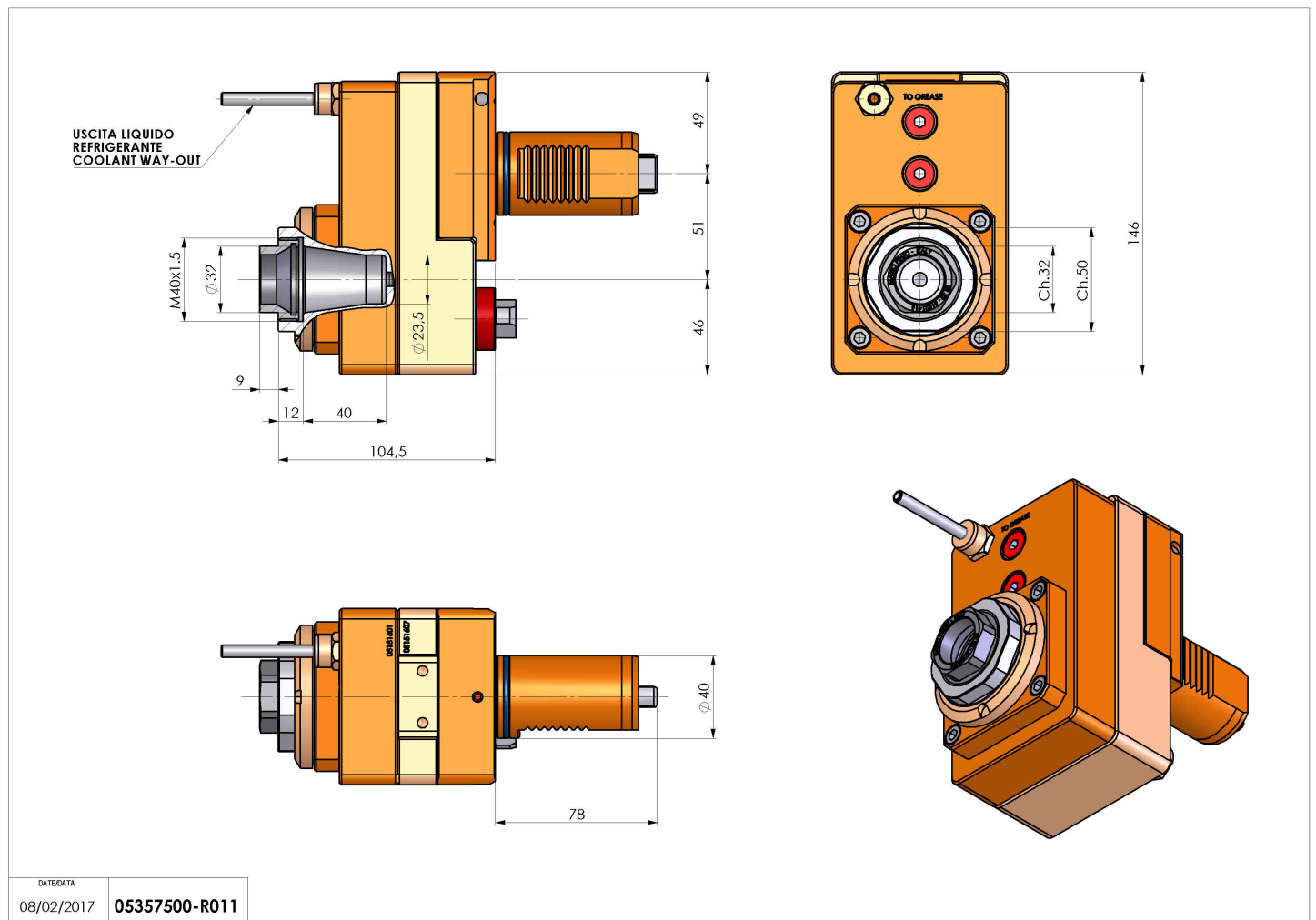

Subject to technical changes