

## 05357200 - LT-S D80 ER40 OFS100 HRF HS H125

<b>Type</b>	LT-S OFS Tool holder straight offset
<b>Mounting</b>	CYLINDRICAL SHANK 80
<b>Tool output</b>	Collet nut ER 40
<b>Coolant</b>	HRF Internal coolant
<b>Offset [mm]</b>	100
<b>Direction of rotation</b>	r1  r2
<b>Max speed [rpm]</b>	10000
<b>Max torque [Nm]</b>	80
<b>Ratio</b>	1:1
<b>H [mm]</b>	125
<b>Max pressure [bar]</b>	80
<b>Accessories</b>	N.A.
<b>Notes</b>	N.A.
<b>Mounting tips</b>	N.A.

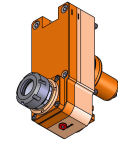

Always check live tool dimensions on the turret

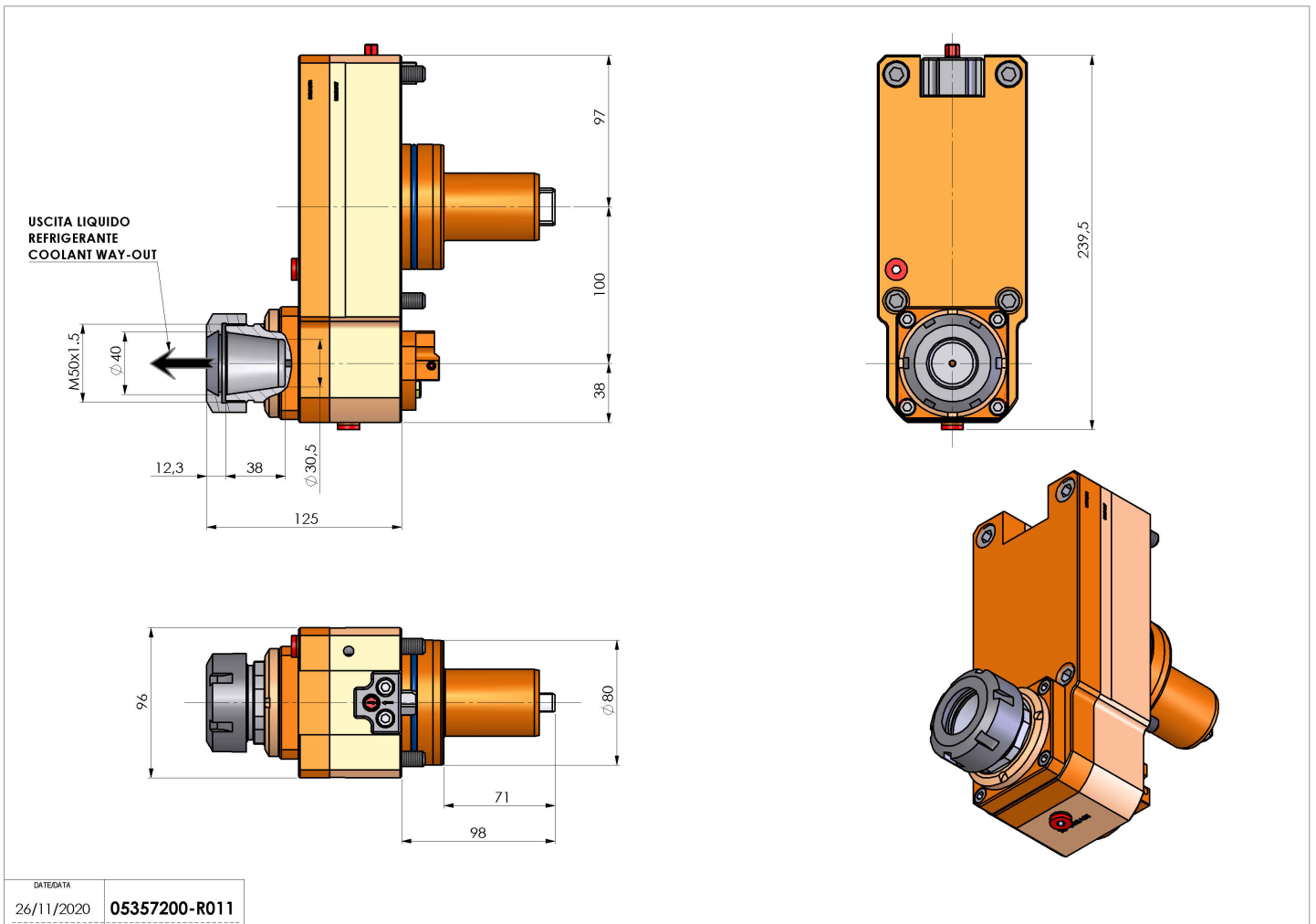

DATE/DATE	26/11/2020
PART NUMBER	05357200-R011

Subject to technical changes